



Silaba Directa

ma me mi

mo mu



Fecha:



Sigue con tu dedo el trazo de la letra y luego remárcala con 5 colores diferentes:

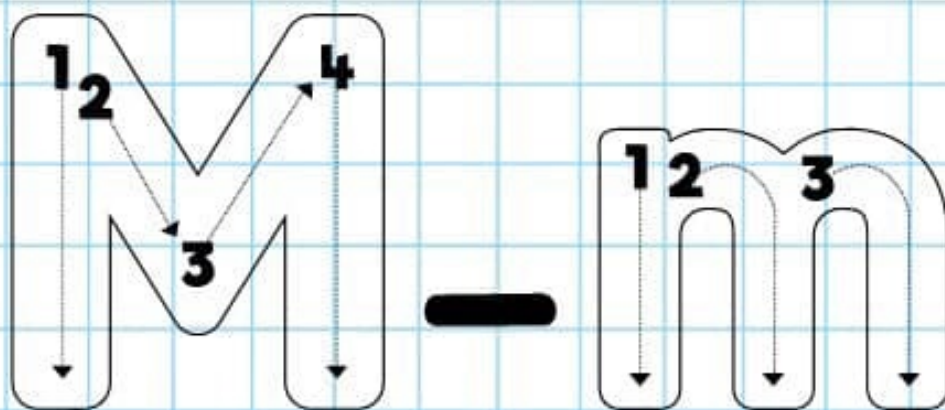

Pronuncia la letra más la vocal y descubre la sílaba que se forma:

m + a suena → ma



m + e suena → me



m + i suena → mi



m + o suena → mo



m + u suena → mu



Fecha:



Lee las siguientes sílabas, palabras y oraciones:



ma



mi



me



mu



mo

ama

mami

mima

mimo

mamá

amo

Ema

Memo

Mimí

Memo me mima.

Mi mamá me ama.

Amo a mi mamá.



Fecha:



Une la ilustración con su sílaba inicial:



ma



me



mi



mo



mu



Fecha:



Encierra la sílaba con la que inicia cada dibujo:



ma mo mi mu



mi ma mu mo



mu mi mo ma



mi mu me mo



mo ma mi me



mu mo me



Fecha:



Completa las palabras:



--dusa



--sa



--ela



--no



--to



--el



--má



--leta



Fecha:



Anota en el espacio correspondiente las palabras que inicien con la sílaba correspondiente:

ma

me

mi

mo

mu

mesa

masa

maleta

mimo

mono

moño

mano

música

Memo

meta

misa

moto

<https://www.facebook.com/groups/miss.arheli>



Fecha:



Copia en la raya las oraciones:

Memo me ama a mi.

Amo a mi mamá.

Ema y Memo.

Mi mami Ema.

Mi mami me ama y me mima.

<https://www.facebook.com/groups/miss.arheli>





Silaba Directa

la le li

lo lu







Fecha:

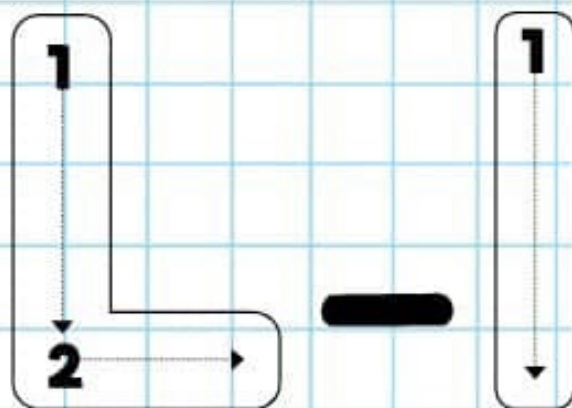

Sigue con tu dedo el trazo de la letra y luego remárcala con 5 colores diferentes:

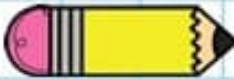

Pronuncia la letra más la vocal y descubre la sílaba que se forma:

l	+	a	suena	→	la	
l	+	e	suena	→	le	
l	+	i	suena	→	li	
l	+	o	suena	→	lo	
l	+	u	suena	→	lu	



Fecha:



Lee las siguientes sílabas, palabras y oraciones:



la

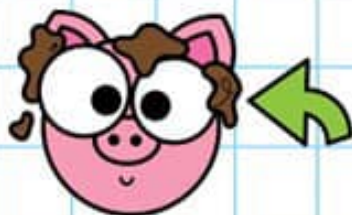

lo



lu



li



le

Luli

ola

mala

ala

mole

lima

Mili

Lala

loma

mila

lame

limón

lolo

Lila

Lalo

Uli

La mula Lola.

La muela me duele.

Lili me lee.



<https://www.facebook.com/groups/miss.arheli>

Fecha:



Une la ilustración con su sílaba inicial:



la



le



li



lo

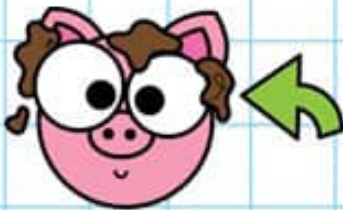

lu



Fecha:



Encierra la sílaba con la que inicia cada dibujo:



la lo li lu



li la lu lo



lu li lo la



li lu le lo



lo la li le



lu lo le la



Fecha:



Completa las palabras:



--piz



--bro



--ma



--ón



--na



--do



--be---



--pa



Fecha:



Anota en el espacio correspondiente las palabras que inicien con la sílaba correspondiente:

la

le

li

lo

lu

Lola

lima

lupa

lee

lila

Lili

loma

leo

lodo

Lalo

lápiz

luna

<https://www.facebook.com/groups/miss.arheli>



Fecha:



Une la palabra con el dibujo correcto:



lupa



loma



lápiz



luna



lodo



libro

<https://www.facebook.com/groups/miss.arhely>



Fecha:



Copia en la raya las oraciones:

Mi mamá me mima.

Lalo me lee.

Eli lame la miel.

La miel de Amelia.

La mula mala en la loma.

<https://www.facebook.com/groups/miss.arheli>





Silaba Directa

sa se si

so su



Fecha:



Sigue con tu dedo el trazo de la letra y luego remárcala con 5 colores diferentes:

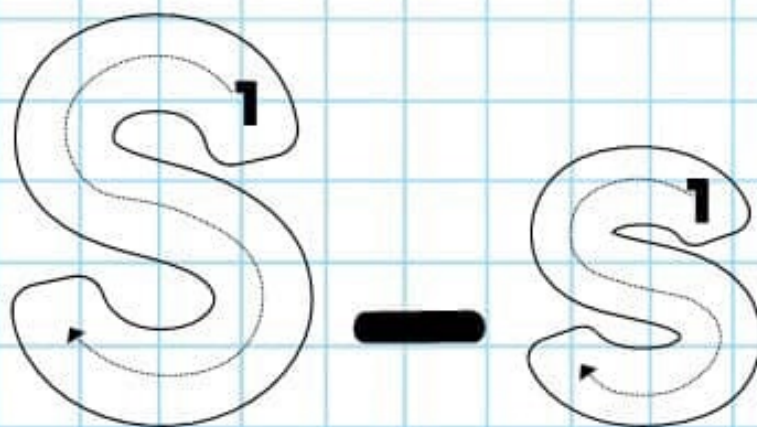

Pronuncia la letra más la vocal y descubre la sílaba que se forma:

s + a suena → sa



s + e suena → se



s + i suena → si



s + o suena → so



s + u suena → su



Fecha:



Lee las siguientes sílabas, palabras y oraciones:



sa

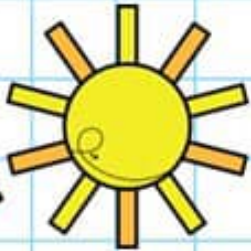

so



si



su



se

masa

sol

liso

amasa

Susi

misa

suma

sala

mesa

Melisa

los

más

sal

misa

solo

osos

Susi amasa la masa.

Los osos son malosos.

El sol sale.



Fecha:



Une la ilustración con su sílaba inicial:



sa



se

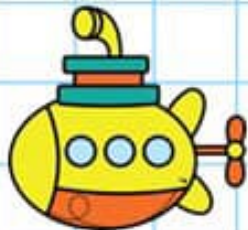

si



so



su



Fecha:



Encierra la sílaba con la que inicia cada dibujo:



sa

so

si

su



si

sa

su

so



su

si

so

sa



si

sa

se

so



so

sa

si

se



su

so

se



Fecha:



Completa las palabras:

6

--is



--bmarino



--rena



o--



--rrucho

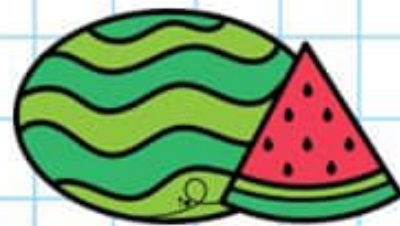

--ndía



--mbrilla



--l



Fecha:



Anota en el espacio correspondiente las palabras que inicien con la sílaba correspondiente:

sa

se

si

so

su

sol

Susi

suma

sala

sal

solo

serpiente

simio

sonaja

silbar

seis

soldado

<https://www.facebook.com/groups/miss.arhely>



Fecha:



Une la palabra con el dibujo correcto:



sirena



semáforo



oso



serrucho



seis

6

submarino

<https://www.facebook.com/groups/miss.arheli>



Fecha:



Copia en la raya las oraciones:

Esa mesa es mía.

Susi ama a su mamá.

Ese oso se asoma.

Eli amasa la masa.

Los osos son malosos.

<https://www.facebook.com/groups/miss.arheli>





Silaba Directa

ta te ti

to tu







Fecha:

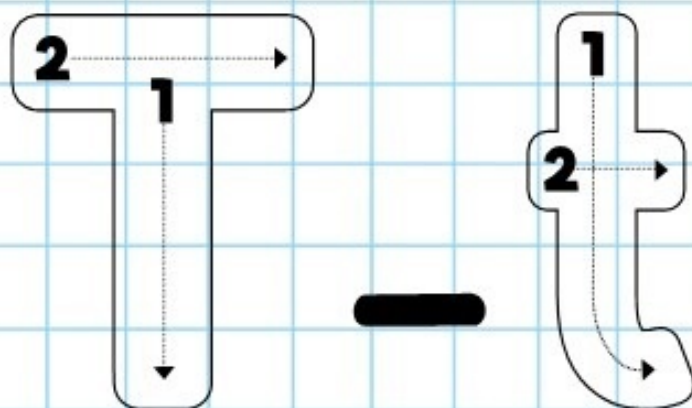

Sigue con tu dedo el trazo de la letra y luego remárcala con 5 colores diferentes:



Pronuncia la letra más la vocal y descubre la sílaba que se forma:

t	+	a	suena	→	ta	
t	+	e	suena	→	te	
t	+	i	suena	→	ti	
t	+	o	suena	→	to	
t	+	u	suena	→	tu	



Fecha:



Lee las siguientes sílabas, palabras y oraciones:



tu



ta

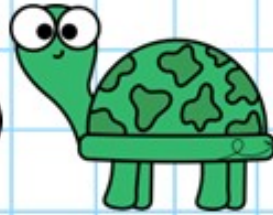

to



te



ti

tomate

tele

Tito

maleta

luto

tema

moto

tose

lista

atole

salta

meta

Tomasa

mete

tela

tos

Tomasa mete su maleta.

Mi tía muele el tomate.

Tito usa su moto.



Fecha:



Une la ilustración con su sílaba inicial:

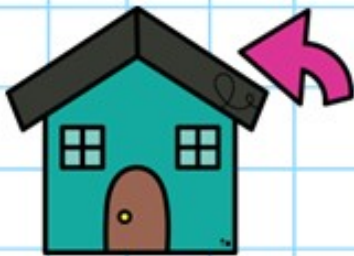

ta

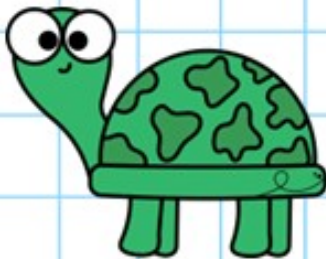

te



ti



to



tu



Fecha:



Encierra la sílaba con la que inicia cada dibujo:



ta

to

ti

tu



ti

ta

tu

to



tu

ti

to

ta



te

ta

ti

to



to

tu

ti

te



ta

to

te



Fecha:



Completa las palabras:



--cón



--gre



--léfono

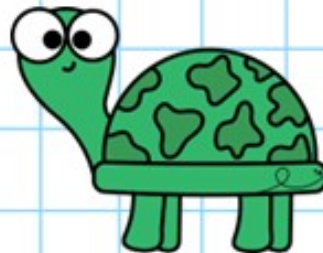

--rtuga



--na



--za



--lipanes



--bogán



Fecha:



Anota en el espacio correspondiente las palabras que inicien con la sílaba correspondiente:

ta

te

ti

to

tu

tomate

tucán

Tito

tose

tema

timón

tamal

taladro

tos

Tomasa

tulipán

tela



Fecha:



Une la palabra con el dibujo correcto:



taza



tina



tigre



teléfono



tortuga



tobogán



Fecha:



Copia en la raya las oraciones:

Tomasa mete su maleta.

Memo usa muletas.

Mi tía muele el tomate.

Melisa tiene tos.

Tito usa su moto.





Silaba Directa

fa fe fi

fo fu



Fecha:



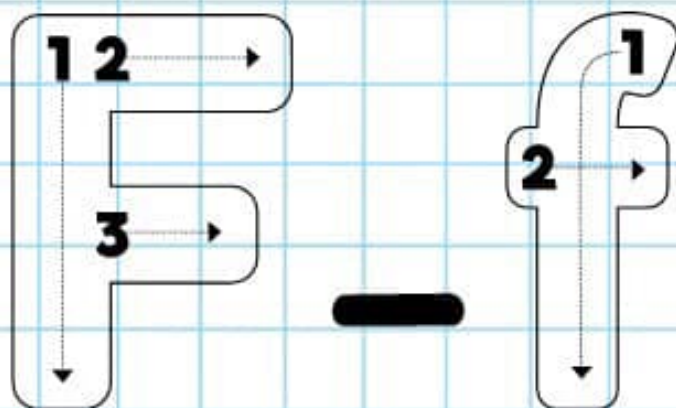

Sigue con tu dedo el trazo de la letra y luego remárcala con 5 colores diferentes:





Pronuncia la letra más la vocal y descubre la sílaba que se forma:

f + a suena → fa 

f + e suena → fe 

f + i suena → fi 

f + e suena → fo 

f + u suena → fu 



Fecha:



Lee las siguientes sílabas, palabras y oraciones:



fa



fe



fi



fo



fu

feo

famoso

falta

foto

fiesta

fomi

fosa

familia

falda

Fátima

fama

fila

fósil

Felisa

sofá

Sofía

Fátima es famosa.

La familia se tomó la foto.

Lalo fue a la fiesta de **S**ofía.



Fecha:



Une la ilustración con su sílaba inicial:



fa

fe

fi

fo

fu



Fecha:



Encierra la sílaba con la que inicia cada dibujo:



fa

fe

fi

fu



fi

fa

fu

fo



fu

fi

fo

fa



fo

fa

fi

fe



fi

fo

fi

fe



fa

fi

fe



<https://www.facebook.com/groups/miss.arheli>



Fecha:



Completa las palabras:



--liz



--ego



--ente



--lda



--to



--la



--co



--esta



Fecha:



Anota en el espacio correspondiente las palabras que inicien con la sílaba correspondiente:

fa

fe

fi

fo

fu

feo

famoso

fiel

fiesta

fomi

fosa

falda

fuego

fama

fósil

Felisa

fuelle

<https://www.facebook.com/groups/miss.arheli>



Fecha:



Une la palabra con el dibujo correcto:



fuente



fila



foco



fuego



foto



feliz

<https://www.facebook.com/groups/miss.arheli>



Fecha:



Copia en la raya las oraciones:

Fátima es famosa.

Lalo fue a la fiesta de Sofía.

La familia se tomó una foto.

Saúl solfea la melodía.

La mamá de Fausto toma soda.

<https://www.facebook.com/groups/miss.arheli>





Silaba Directa

pa pe pi

po pu



Fecha:



Sigue con tu dedo el trazo de la letra y luego remárcala con 5 colores diferentes:

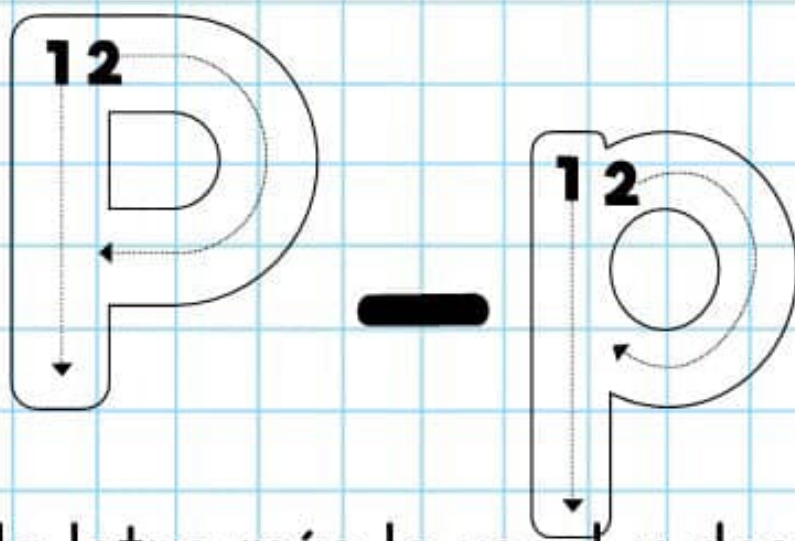



Pronuncia la letra más la vocal y descubre la sílaba que se forma:

p + a suena → pa 

p + e suena → pe 

p + i suena → pi 

p + o suena → po 

p + u suena → pu 



Fecha:



Lee las siguientes sílabas, palabras y oraciones:



pa



pe



pi



po

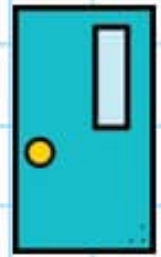

pu

papá

mapa

pela

paloma

palo

puma

pelo

lupa

pomada

paleta

pálido

patada

papel

pulpo

paso

pulido

Papá lee el mapa.

Pamela es modelo de faldas.

La paloma ama al palomo.



Fecha:



Une la ilustración con su sílaba inicial:



pa

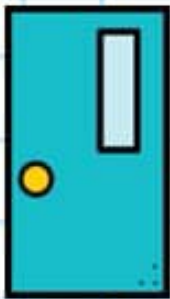

pe



pi



po



pu



Fecha:



Encierra la sílaba con la que inicia cada dibujo:



pa

pe

pi

pu



pi

pu

pa

po



pu

pa

po

pi



po

pa

pi

pu



pe

pu

po

pa

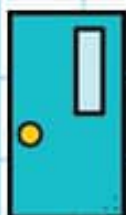

pu

po

pe



Fecha:



Completa las palabras:



--rro



--ano



--z



--no

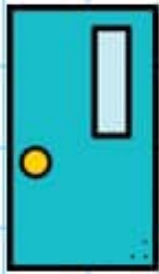

--erta



--llito

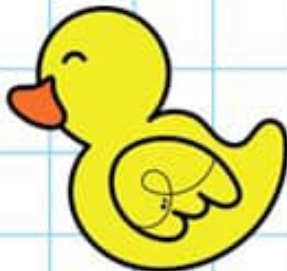

--to



--lpo



Fecha:



Anota en el espacio correspondiente las palabras que inicien con la sílaba correspondiente:

pa

pe

pi

po

pu

papá

piano

pela

pizza

puma

puerta

pomada

paleta

policía

papel

pulpo

pelo



Fecha:



Une la palabra con el dibujo correcto:

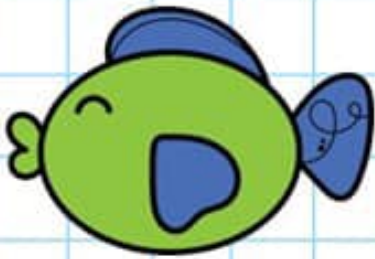

perro



pino

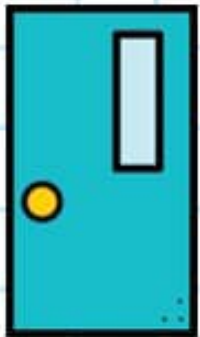

paleta



pez



policia



puerta



Fecha:



Copia en la raya las oraciones:

Papá lee el mapa.

Paola estudia los pulpos.

Pamela es modelo de faldas.

El sapo está asustado.

La paloma ama al palomo.

<https://www.facebook.com/groups/miss.arheli>





Silaba Directa

na ne ni

no nu



Fecha:



Sigue con tu dedo el trazo de la letra y luego remárcala con 5 colores diferentes:

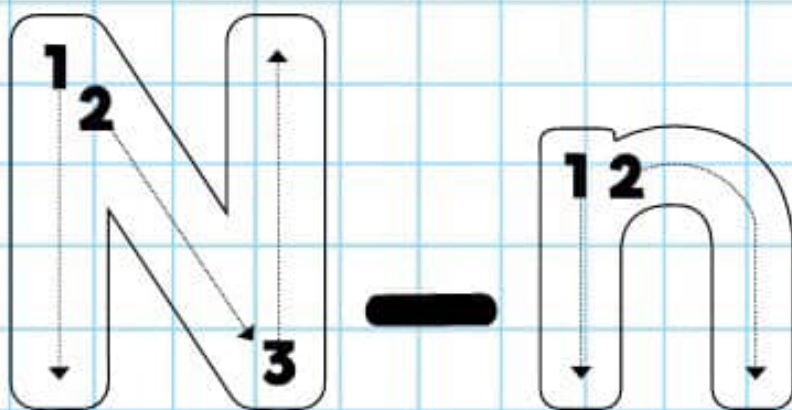

Pronuncia la letra más la vocal y descubre la sílaba que se forma:

n + a suena → na



n + e suena → ne



n + i suena → ni



n + o suena → no



n + u suena → nu



Fecha:



Lee las siguientes sílabas, palabras y oraciones:



na



ne



ni



no



nu

nudo

luna

nana

uno

nido

mono

Noé

pino

mano

suena

pan

león

lona

melón

Nemo

Noelia

Noelia tiene un mantel.

La luna está llena.

La nana limpia las tunas.



Fecha:



Une la ilustración con su sílaba inicial:



na



ne



ni



no

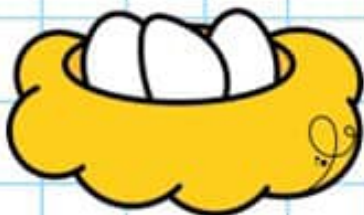

nu



Fecha:



Encierra la sílaba con la que inicia cada dibujo:



na

ne

ni

nu



ni

nu

na

no



nu

na

no

ni



no

na

ni

nu



ne

ni

nu

na



nu

no

ne

ni



Fecha:



Completa las palabras:



--var



--do



--ta



--mo



--ño



--be



--eve



--dar



Fecha:



Anota en el espacio correspondiente las palabras que inicien con la sílaba correspondiente:

na

ne

ni

no

nu

nudo

nadar

nana

nido

nevar

Noé

Noelia

nieve

nómada

nueve

nube

Nemo



Fecha:



Une la palabra con el dibujo correcto:



nueve



niño



nadar



nido



nota



Nemo



Fecha:



Copia en la raya las oraciones:

La nana limpia las tunas.

Pásame el peine.

Los tenis de Noelia.

Tina tiene una nana.

La luna está llena.

<https://www.facebook.com/groups/miss.arheli>





Silaba Directa

ba be bi

bo bu



Fecha:



Sigue con tu dedo el trazo de la letra y luego remárcala con 5 colores diferentes:

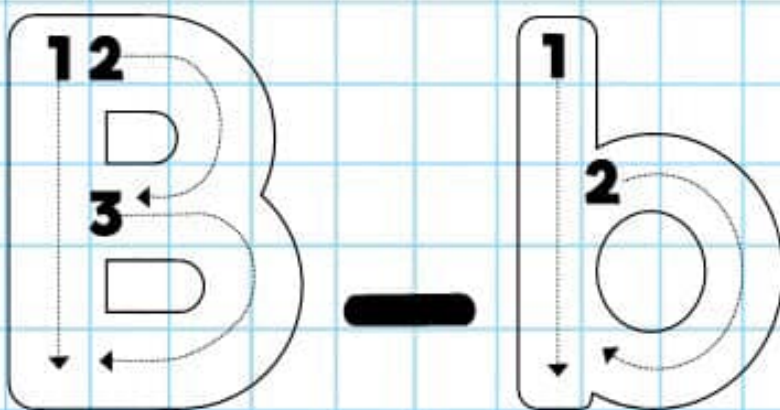



Pronuncia la letra más la vocal y descubre la sílaba que se forma:

b + a suena → ba 

b + e suena → be 

b + i suena → bi 

b + o suena → bo 

b + u suena → bu 



Fecha:



Lee las siguientes sílabas, palabras y oraciones:



ba



be



bi



bo

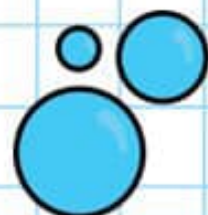

bu

bata

bala

banana

bebé

beso

bota

bombón

bueno

botón

balón

bailan

bote

bolsa

bueno

bonito

abuelo

Mi papá me da un beso.

El abuelo usa botas bonitas.

Mi mamá besa al bebé.



Fecha:



Une la ilustración con su sílaba inicial:



ba

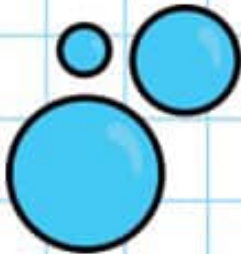

be



bi



bo

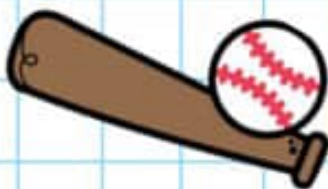

bu



Fecha:



Encierra la sílaba con la que inicia cada dibujo:



ba

be

bi

bu



bi

bu

ba

bo



bu

ba

bo

be



bo

ba

bi

bu



be

bu

bo

ba



bu

bo

be

bi



Fecha:



Completa las palabras:

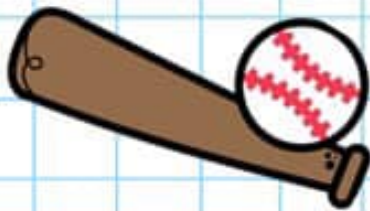

--isbol



--llena



--rro

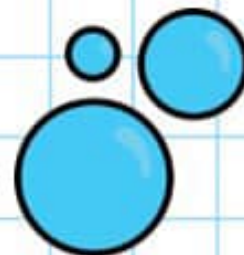

--rbujas



--ca



--bé



--tón



--gote



Fecha:



Anota en el espacio correspondiente las palabras que inicien con la sílaba correspondiente:

ba

be

bi

bo

bu

bata

bailan

bebé

beso

burro

bigote

botón

bicicleta

burbuja

bolsa

bueno

ballena



Fecha:



Une la palabra con el dibujo correcto:



barco



beso



bicicleta



burro



bebé



botón

<https://www.facebook.com/groups/miss.arheli>



Fecha:



Copia en la raya las oraciones:

Mi papá me da un beso.

Melisa silba una melodía.

El abuelo usa botas bonitas.

Benito pateó el balón de fútbol.

Mi mamá besa al bebé.

<https://www.facebook.com/groups/miss.arheli>





Silaba Directa

ja je ji

jo ju



Fecha:



Sigue con tu dedo el trazo de la letra y luego remárcala con 5 colores diferentes:

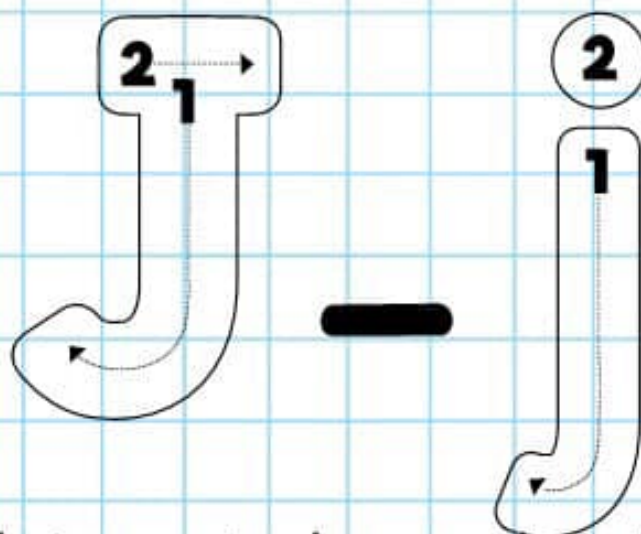

Pronuncia la letra más la vocal y descubre la sílaba que se forma:

j + a suena → ja



j + e suena → je



j + i suena → ji



j + o suena → jo

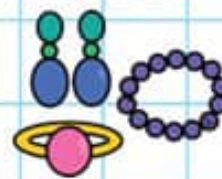

j + u suena → ju



Fecha:



Lee las siguientes sílabas, palabras y oraciones:



ja

je

ji

jo

ju

jaula

jabón

Julia

jefe

jade

justo

jamás

jitomate

Japón

jabalí

jinete

jubilado

junio

junta

jaiba

juanete

Juana se enjabona con la esponja.

Julia juntó unos jitomates.

El espejo de Jimena es lujoso.



Fecha:



Une la ilustración con su sílaba inicial:

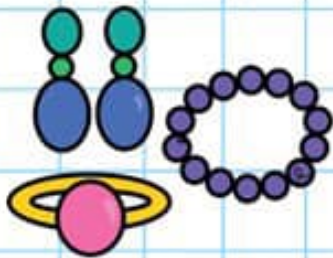

ja



je



ji



jo



ju



Fecha:



Encierra la sílaba con la que inicia cada dibujo:



ja

je

ji

ju



ji

ju

ja

jo



je

ja

jo

ji



jo

ja

ji

je

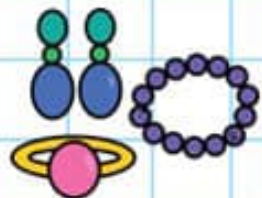

je

ju

jo

ja



ja

jo

je



Fecha:



Completa las palabras:



--rra

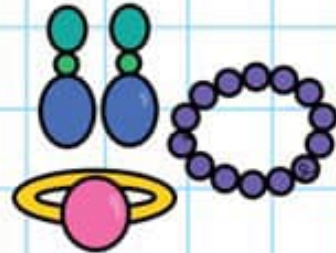

--yas



--rafa



--tomate



--fe



--go



--rdin



--ringa

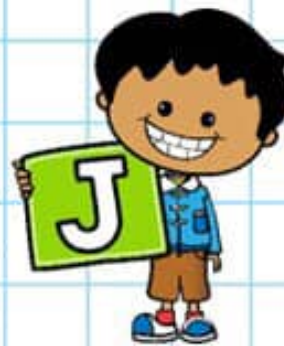

Fecha:



Anota en el espacio correspondiente las palabras que inicien con la sílaba correspondiente:

ja

je

ji

jo

ju

jaula

jefe

Julia

jeringa

justo

joroba

Japón

Josué

jinete

junio

jirafa

jaiba

<https://www.facebook.com/groups/miss.arhely>



Fecha:



Une la palabra con el dibujo correcto:



jitomate

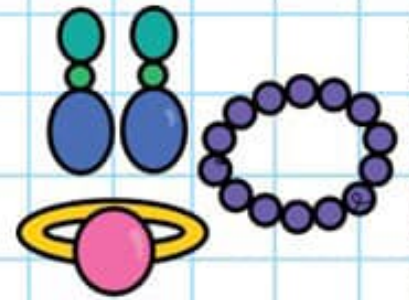

joyas



jefe



jarra

jirafa



jugo



Fecha:



Copia en la raya las oraciones:

Le deje un mensaje a José.

El jefe de Jaime es justo.

Juana se enjabona con la esponja.

El espejo de Jimena es lujoso.

Julia juntó unos jitomates.

<https://www.facebook.com/groups/miss.arheli>





Silaba Directa

ra re ri

ro ru



Fecha:



Sigue con tu dedo el trazo de la letra y luego remárcala con 5 colores diferentes:

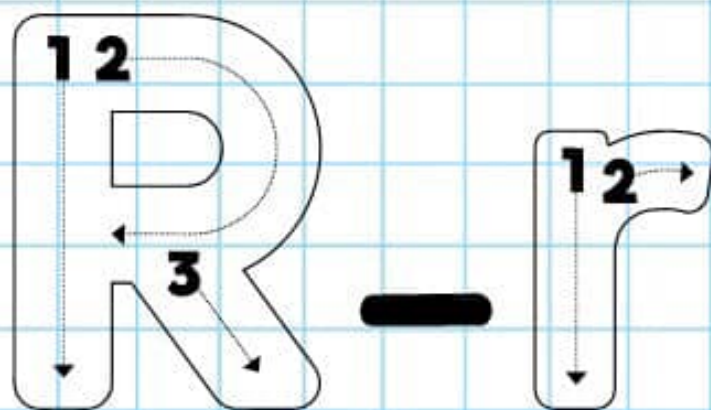

Pronuncia la letra más la vocal y descubre la sílaba que se forma:

r + a suena → ra



r + e suena → re



r + i suena → ri

r + o suena → ro



r + u suena → ru



Fecha:



Aprendamos algunas reglas básicas para leer la letra **R** - **r**

Cuando la **r** va al principio de la
palabra suena fuerte como en **r**atón,
rosa y **r**ana.



ratón



rosa



rana

<https://www.facebook.com/groups/miss.arheli>



Fecha:



Lee las siguientes sílabas, palabras y oraciones:



ra



re



ri



ro



ru

rama

reina

risa

rosa

rubio

rana

río

robot

rueda

rutina

rodeo

ratón

res

roto

reno

reja

La ropa de mujer está en rebaja.

Romina dibuja un rombo.

El ratón camina rápido.



Fecha:



Une la ilustración con su sílaba inicial:



ra



re



ri



ro

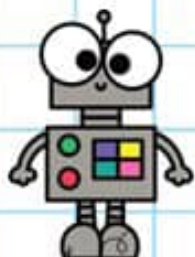

ru



Fecha:



Encierra la sílaba con la que inicia cada dibujo:



ra

re

ri

ru



ri

ra

ru

ro



ru

ra

ro

ri



re

ra

ri

ru



re

ru

ro

ra



ru

ro

re

ri



Fecha:



Completa las palabras:

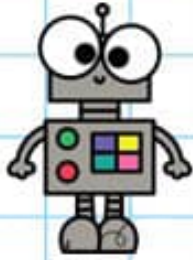

--bot



--sa



--bio



--galo



--na



--ina



--sa



--o



Fecha:



Anota en el espacio correspondiente las palabras que inicien con la sílaba correspondiente:

ra

re

ri

ro

ru

rama

reina

risa

rubio

rana

río

rueda

rutina

rodeo

res

roto

reno



Fecha:



Une la palabra con el dibujo correcto:



rueda



robot



risa



río



rama

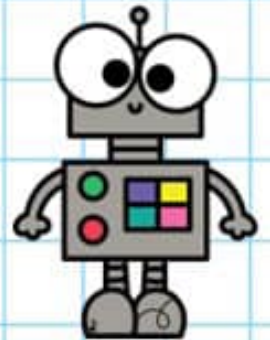

reina



Fecha:



Copia en la raya las oraciones:

La ropa de mujer está en rebaja.

Rosa es la reina de las rimas.

Romina dibuja un rombo.

El ruido de la radio molesta a Rita.

El ratón camina rápido.

<https://www.facebook.com/groups/miss.arheli>





Silaba Directa (sonido suave)

ra re ri

ro ru



Fecha:



Aprendamos algunas reglas básicas para leer la letra **R - r**

Cuando la **r** va entre 2 vocales suena suave como en **toro**, **loro** y **pera**.

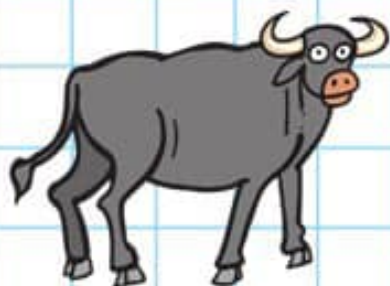

toro



loro



pera

<https://www.facebook.com/groups/miss.arheli>



Fecha:



Lee las siguientes sílabas, palabras y oraciones:



cámar**a**



aren**a**



mar**i**posa



coron**a**

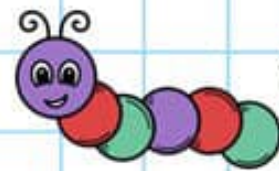

orug**a**

palmera

enero

madera

toro

mandarina

Sara

número

pera

pirata

esfera

naranja

Laura

mariposa

arena

loro

parada

El pirata tiene un loro.

Sara tira el papel a la papelera.

El marinero miro una sirena.



<https://www.facebook.com/groups/miss.arheli>

Fecha:



Une la ilustración con su sílaba correspondiente:



ra



re



ri



ro



ru



Fecha:



Encierra la sílaba que le corresponde a cada dibujo (con ayuda del docente):

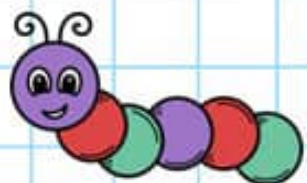

ra

re

ri

ru



ri

ra

ru

ro



ru

ra

ro

ri



re

ra

ri

ru



re

ru

ro

ra



ru

ro

ra

ri



<https://www.facebook.com/groups/miss.arheli>

Fecha:



Identifica cada palabra y escríbela en el espacio que le corresponda:

Sonido fuerte r	Sonido suave r

rama

reina

cara

toro

faro

río

rueda

loro

arena

pera

roto

reno





Silaba Directa (doble r)

rra

rre

rri

rro

rru



Fecha:



Aprendamos algunas reglas básicas para leer la letra **R - r**

Quando queremos que la **r** suene fuerte entre 2 vocales escribimos **rr** como en **perro**, **motosierra** y **tarro**.



perro



tarro



motosierra



Fecha:



Lee las siguientes sílabas, palabras y oraciones:



gorra



carretera



barril



burro

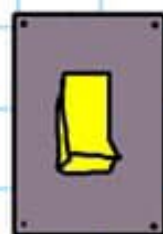

interruptor

perro

tarro

barril

burro

motosierra

irritar

borrar

sierra

parrilla

pedorro

arrollar

barrer

borrador

tierra

párrafo

jarrón

Nora Parra barre el piso de arriba.

El perro arrastra su rabo.

La torre es de fierro.



Fecha:



Completa las palabras:



ba___l



go___



ca___tera



pe___



ta___



inte___ptor



bu___



motosie___



Fecha:



Une la palabra con el dibujo correcto:



tarro



interruptor



gorra



barril

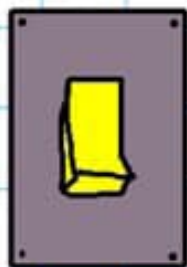

perro



burro

<https://www.facebook.com/groups/miss.arheli>



Fecha:



Copia en la raya las oraciones:

El burrito pasea por la loma.

Los soldados están en la torre.

Pepe borra los dibujos con el borrador.

El tarro está roto.

Raúl amarra el remo.

<https://www.facebook.com/groups/miss.arhely>





Silaba Directa

ha he hi

ho hu



Fecha:



Sigue con tu dedo el trazo de la letra y luego remárcala con 5 colores diferentes:

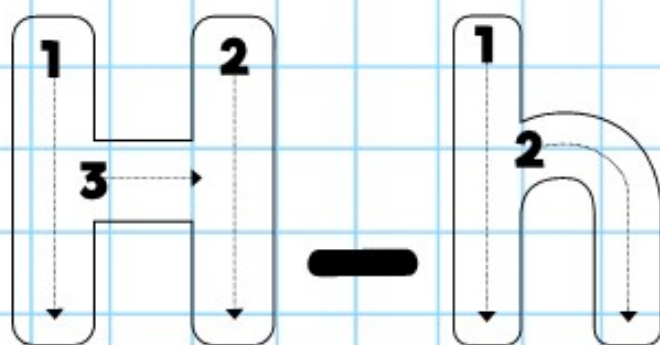

Pronuncia la letra más la vocal y descubre la sílaba que se forma:

h + a suena → ha



h + e suena → he



h + i suena → hi



h + o suena → ho



h + u suena → hu



Fecha:



Lee las siguientes sílabas, palabras y oraciones:

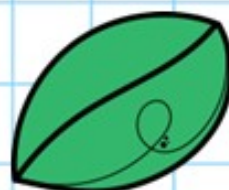

hada helado hipopótamo hoja hueso

humo hilo habas hora

hijo hacha humano huir

hielo humilde hermano héroe

hospital harina ahora huerta

Las hojas caen del pino.

José está en la hamaca.

Usa el hilo para el pantalón.



Fecha:



Une la ilustración con su sílaba inicial:

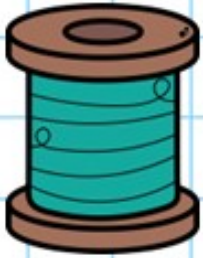

ha



he



hi



ho

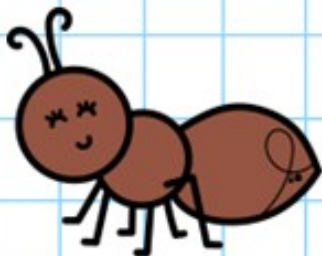

hu



Fecha:



Encierra la sílaba con la que inicia cada dibujo:



ho

he

hi

hu



hi

ha

hu

ho



hu

ha

ho

hi



he

ha

hi

hu



he

hi

ho

ha



hu

ho

he

hi



Fecha:



Completa las palabras:



__lado



re__lete



__spital



__mo

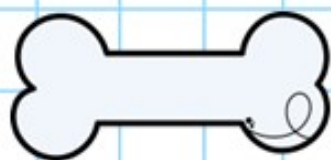

__eso



__rina



__elo



__maca



Fecha:



Anota en el espacio correspondiente las palabras que inicien con la sílaba correspondiente:

ha

he

hi

ho

hu

hermoso

hilo

héroe

helado

hada

hoja

harina

hospital

hueso

huerta

humano

hielo

<https://www.facebook.com/groups/miss.arheli>



Fecha:



Une la palabra con el dibujo correcto:



hospital



hipopótamo



rehilete



hielo



harina



hoja

<https://www.facebook.com/groups/miss.arhely>



Fecha:



Copia en la raya las oraciones:

L a h i e n a s e r í e d e l h i p o p ó t a m o .

H u m b e r t o e s t á e n l a h a m a c a .

H i l d a e s p r i m a d e H o m e r o .

L a s h o j a s c a e n d e l á r b o l .

E l h e r m a n o d e E l e n a l e e .

<https://www.facebook.com/groups/miss.arhely>





Silaba Directa

za ze zi

zo zu



Fecha:



Sigue con tu dedo el trazo de la letra y luego remárcala con 5 colores diferentes:

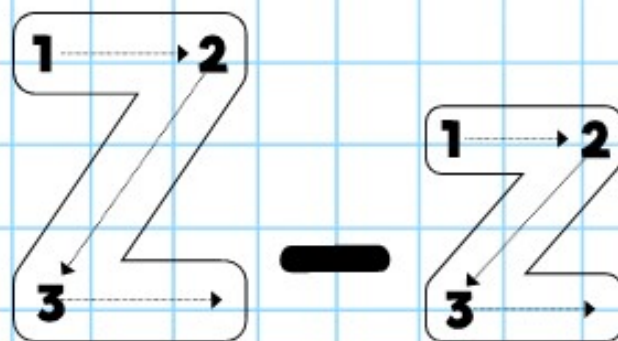

Pronuncia la letra más la vocal y descubre la sílaba que se forma:

Z + a suena → **za** 

Z + e suena → **ze** 

Z + i suena → **zi** 

Z + o suena → **zo** 

Z + u suena → **zu** 



Fecha:



Lee las siguientes sílabas, palabras y oraciones:



Z



zapato

zeta

zigzag

zorro

zumo

zurdo

pozo

taza

pinza

anzuelo

manzana

zafiro

zopilote

Zoe

zona

zanja

zumba

limpieza

mazapán

buzo

nuez

La manzana roja.

Mi corazón late fuerte.

Esos zapatos azules.



Fecha:



Une la ilustración con su sílaba inicial:



za



ze

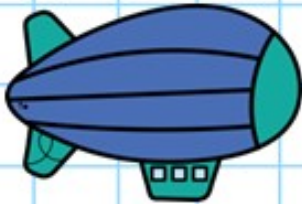

zi

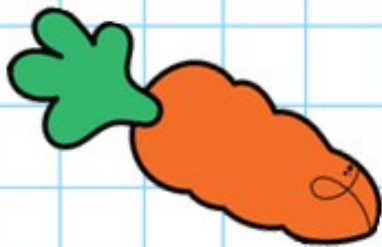

zo



zu



Fecha:



Encierra la sílaba con la que inicia cada dibujo:



za

ze

zi

zu

Z

zi

za

ze

zo



zu

za

zo

zi



ze

za

zi

zu



ze

zu

zo

za



zu

zi

ze

zo



Fecha:



Completa las palabras:

Z

--ta



--mba



--mo



--pato



--pilote



--g--g



--nahoria



--rro



Fecha:



Anota en el espacio correspondiente las palabras que inicien con la sílaba correspondiente:

za

ze

zi

zo

zu

zurdo

pozo

taza

anzuelo

manzana

zafiro

Zoe

zona

zeta

zepelín

zigzag

buzo



Fecha:



Une la palabra con el dibujo correcto:



zopilote

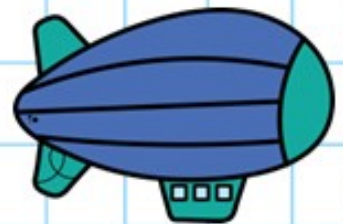

zorro

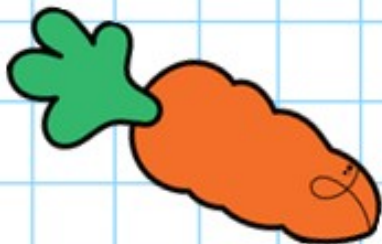

zigzag



zepelín



zumba



zanahoria



Fecha:



Copia en la raya las oraciones:

Mis zapatos son azules.

La manzana es roja.

El zorro come zanahoria.

Dame esa taza.

Hoy fuimos al zoo.

<https://www.facebook.com/groups/miss.arhely>





Silaba Directa

ga ge gi

go gu

gue - gui

güe - güi



Fecha:



Sigue con tu dedo el trazo de la letra y luego remárcala con 5 colores diferentes:

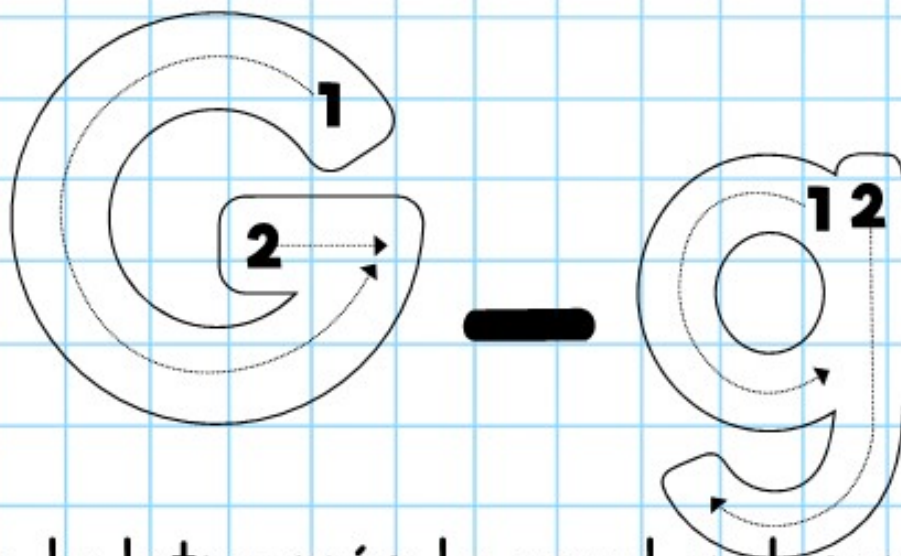

Pronuncia la letra más la vocal y descubre la sílaba que se forma:

g + a suena → ga



g + e suena → ge



g + i suena → gi



g + o suena → go

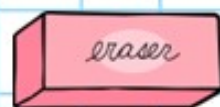

g + u suena → gu



Fecha:



Aprendamos algunas reglas básicas para leer la letra **G** - **g**

La **g** suena fuerte con las vocales **e** - **i**; como en **genio**, **girasol** y **gelatina**.

La **g** suena suave con las vocales **a**, **o**, y **u**; como en **gato**, **golosina** y **guapo**.



genio

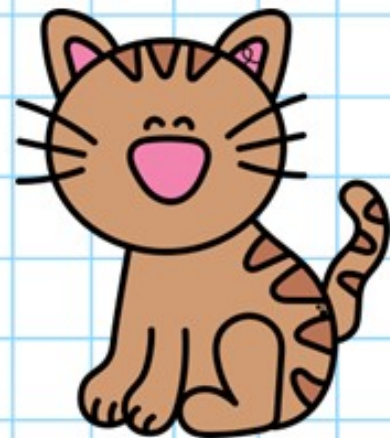

gato



Fecha:



Aprendamos algunas reglas básicas para leer la letra **G** - **g**

Los puntitos sobre
la **ü** se llaman
diéresis y se usan
para que la u
tenga sonido y se
lea así:

Para que la **g**
suene suave con
las vocales **e** - **i**,
debe llevar como
compañera a la u,
o sea **gue** - **gui**.

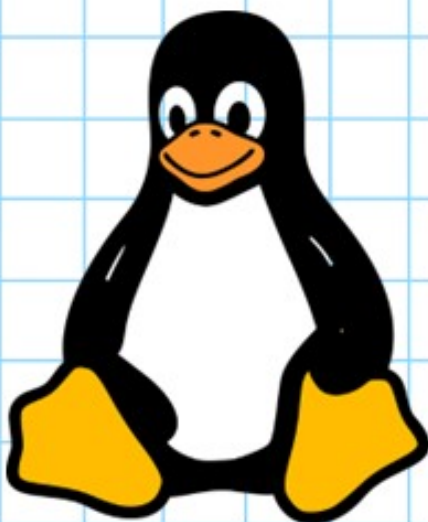

pingüino



guitarra



Fecha:



Lee las siguientes sílabas, palabras y oraciones:

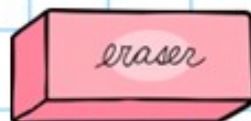

gato **g**elatina **g**irasol **g**oma **g**uante

gasa gota gusano fuego

gol agua gasolina amigo

lengua tortuga pingüino cigüeña

guerrero ceguera guitarra guiño

Sergio es un agente genial.

La tortuga es gigante.

Mi gato toma agua.



Fecha:



Une la ilustración con su sílaba inicial:



ga



ge



gi



go



gu



Fecha:



Encierra la sílaba que corresponda a cada dibujo:



güe

güi

gue

gui



güe

güi

gue

gui



güe

güi

gue

gui



güe

güi

gue

gui



güe

güi

gue

gui



güe

güi

gue

gui

<https://www.facebook.com/groups/miss.arheli>



Fecha:



Completa las palabras:



ci___ña



__tas



__melas



__sano



___tarra

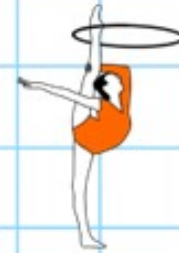

__mnasta

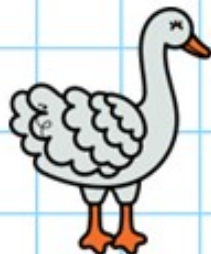

__nso



___rrero



Fecha:



Anota en el espacio correspondiente las palabras que inicien con la sílaba correspondiente:

ga

ge

gi

go

gu

gas

gelatina

gorra

guante

goma

gemelas

ganso

gitana

gato

gigante

gusano

girasol

<https://www.facebook.com/groups/miss.arhely>





Silaba Directa

que qui



Fecha:



¿Recuerdas el cuento anterior?:

“El Castillo de las Letras”

Bueno recordemos que como la letra **C** hizo que se pelearan la **e** y la **i**, éstas fueron castigadas. Por esa razón cuando escribimos **ce** y **ci**, ellas suenan como **se** y **si**, como si fueran **ese**.

ce y **ci**

Entonces el **H**ada de las **P**alabras llamó a la letra **q**, y le pidió ayuda para la letra **c**, para que ésta tuviera un sonido fuerte con **e** y con **i**. La letra **q** le dijo:

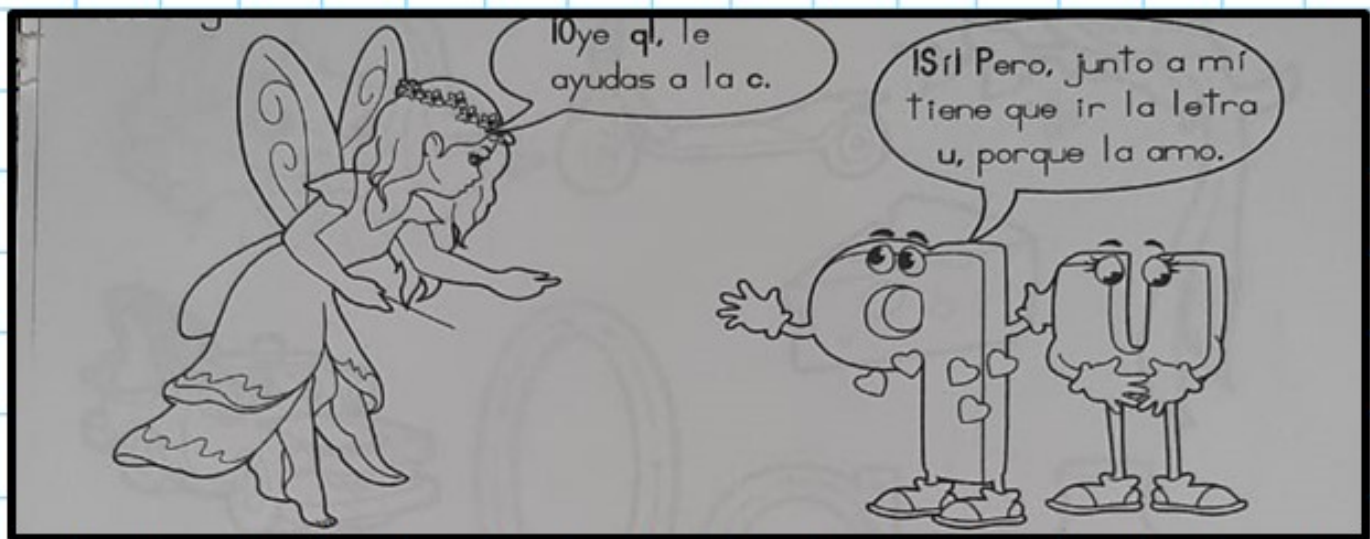

Fecha:



“El Castillo de las Letras”

Desde ese día, las combinaciones de las letras ca, que, qui, co, cu suenan fuerte.

Por fin terminaron las dificultades en el Castillo de las Letras. Ahora está lleno de felicidad.



<https://www.facebook.com/groups/miss.arhely>



Fecha:



Sigue con tu dedo el trazo de la letra y luego remárcala con 5 colores diferentes:

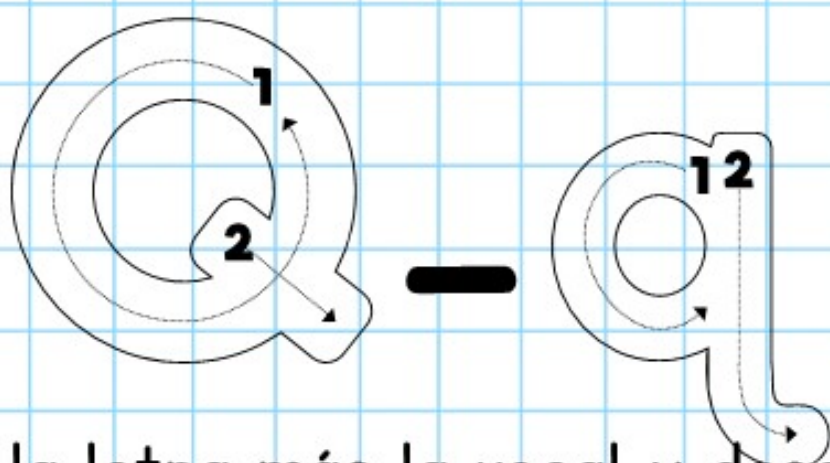

Pronuncia la letra más la vocal y descubre la sílaba que se forma:

qu + e suena → que

qu + i suena → qui

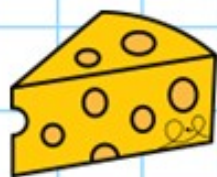

queso

15

quince



Fecha:



Lee las siguientes sílabas, palabras y oraciones:

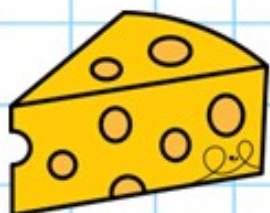

queso quemado quinceañera quinqué

máquina

bosque

maqueta

esqueleto

esquina

mosquito

raqueta

vaquero

esquimal

parque

estanque

quieto

El ratón come queso.

El barquito es de papel.

El venado juega en el bosque.



Fecha:



Une la ilustración con su sílaba inicial:



que

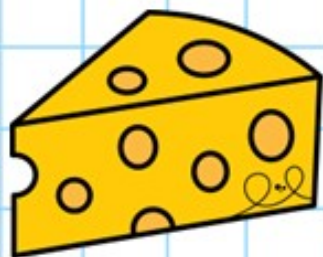

qui



Fecha:



Anota en el espacio correspondiente las palabras que contengan la sílaba correspondiente:

que

qui

máquina

bosque

maqueta

esqueleto

esquina

mosquito

raqueta

vaquero

esquimal

parque

estanque

quieto



Fecha:



Une la palabra con el dibujo correcto:

15

bosque

queso



vaquero

esqueleto



raqueta

quince

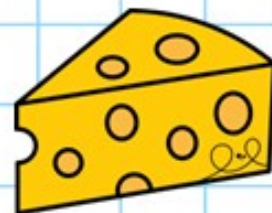

<https://www.facebook.com/groups/miss.arhely>



Fecha:



Copia en la raya las oraciones:

La orquesta del teatro.

Su cabaña es pequeña.

El ratón se viste de vaquero.

Los mosquitos pican mucho.

En la esquina venden galletas.

<https://www.facebook.com/groups/miss.arhely>

