

Atención a la diversidad

Material fotocopiable



Proyecto didáctico

Equipo de Educación Infantil de Ediciones SM

Revisión pedagógica y coordinación editorial

Elena Correa, Cristina Ulloa

Ilustración

Cristina Pérez

Diseño y maquetación

Equipo SM

Dirección editorial

Francis Berdugo

© Ediciones SM

ÍNDICE



ÍNDICE POR UNIDADES

Unidad 1: 4, 5, 6, 7, 8, 9

Unidad 2: 10, 11, 12, 13, 14

Unidad 3: 15, 16, 17, 18, 19

Unidad 4: 20, 21, 22, 23, 24, 25, 26, 27, 28, 29

Unidad 5: 30, 31, 32, 33, 34, 35, 36

Unidad 6: 37, 38, 39, 40, 41, 42

Unidad 7: 43, 44, 45

Unidad 8: 46, 47, 48, 49, 50, 51, 52, 53

Unidad 9: 54, 55, 56, 57, 58, 59, 60, 61, 62, 63

ÍNDICE POR CONTENIDOS

Medida

- Más grande / más pequeño: 9
- Grande, mediano, pequeño: 21
- Lleno/vacío: 16
- Ligero/pesado: 41
- Más alto que / más bajo que: 53

Números

- Número 1: 4
- Número 2: 7
- Número 3: 11
- Número 4: 20, 22, 25
- Número 5: 33, 35, 45
- Número 6: 50, 51, 54
- Número 7: 63
- Números del 1 al 3: 14, 25
- Números del 1 al 4: 27, 28, 29, 39
- Números del 1 al 5: 37
- Números del 1 al 6: 57
- Números 4, 5 y 6: 59
- Ordinales (1.º y último): 17
- Ordinales (1.º, 2.º y 3.º): 31

Operaciones

- Sumas: 43, 48, 56, 61

Cuantificación

- Muchos/pocos: 6
- Todos/algunos: 12
- Ninguno: 17
- Tantos como: 36
- Más que / menos que: 40, 42

Resolución de problemas

- Tabla de doble entrada: 21
- Reconocimiento de propiedades: no es / sí es: 13, 55

Series

- Series con dos elementos: 24
- Series con dos y tres elementos: 47

Conceptos espaciales

- Cerca/lejos: 32
- A un lado / a otro lado: 26
- De frente / de espaldas: 39
- Alrededor: 40
- Entre: 46
- Izquierda/derecha: 60

Conceptos temporales

- Mañana/tarde/noche: 31

Geometría

- El rectángulo: 13
- La esfera: 15
- Líneas rectas / líneas curvas: 16

Capacidades

- Atención: 5, 10, 18, 30, 45, 57
- Percepción: 8, 52, 62
- Memoria: 58
- Pensamiento creativo: 15, 19, 38, 44
- Relaciones lógicas: 13, 21, 23, 30, 34, 49, 55

- Repasar y completar las grafías del 1.
- Unir el número 1 con la imagen que corresponde y colorearla.

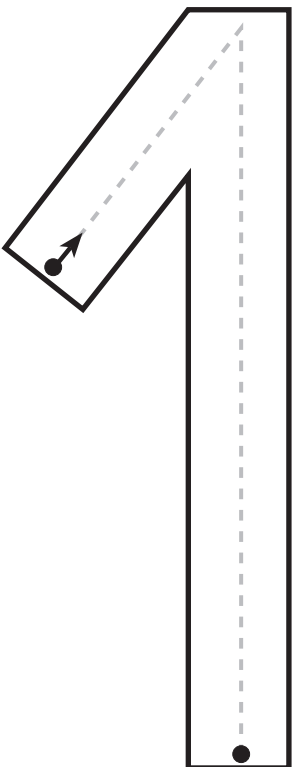
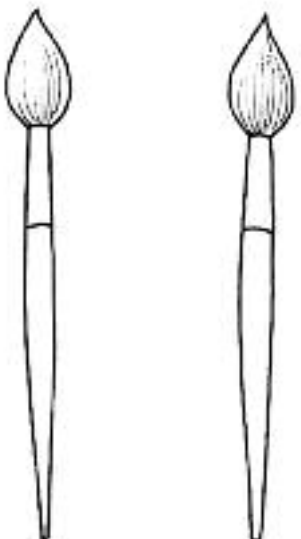
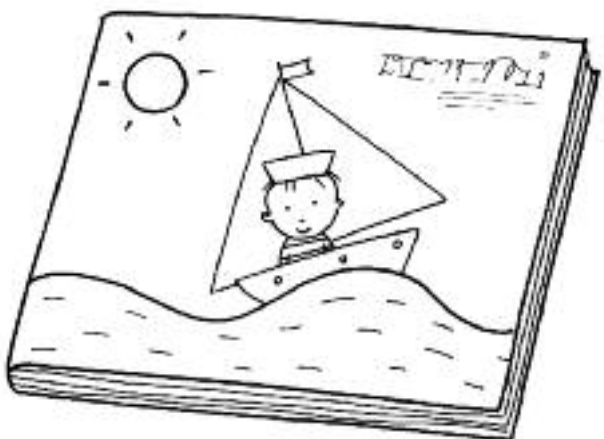
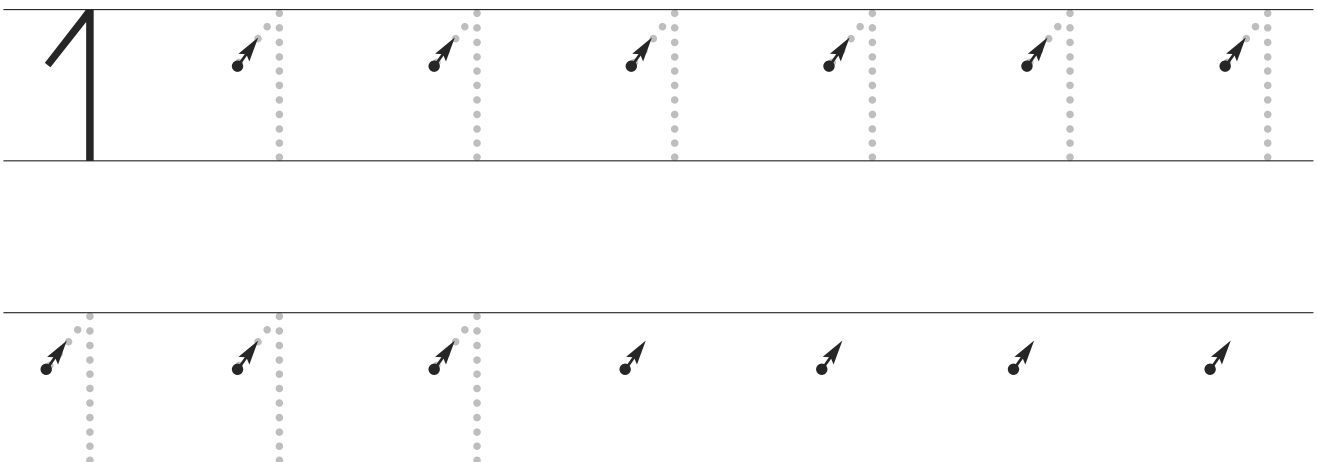

- Rodear el dibujo que es igual al modelo.

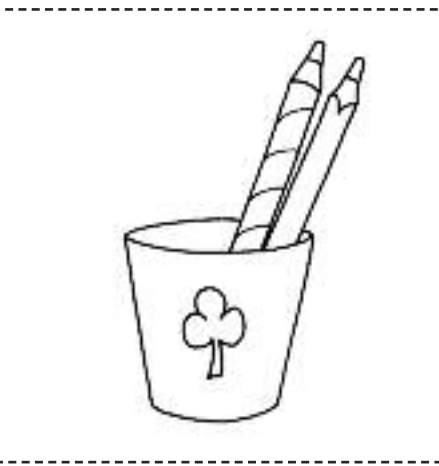
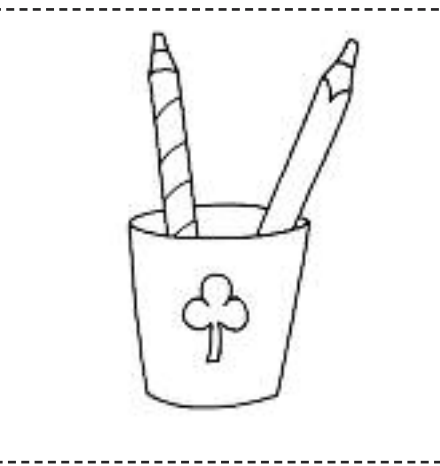
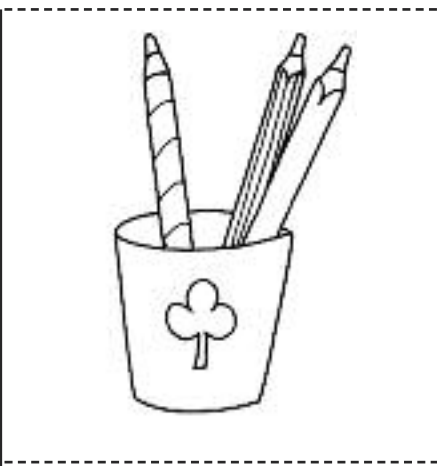
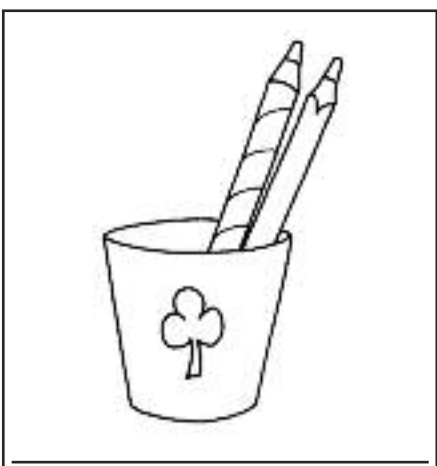
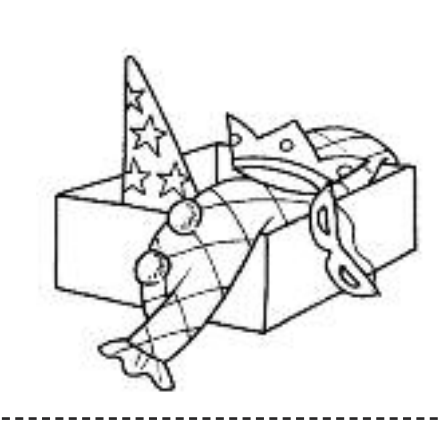
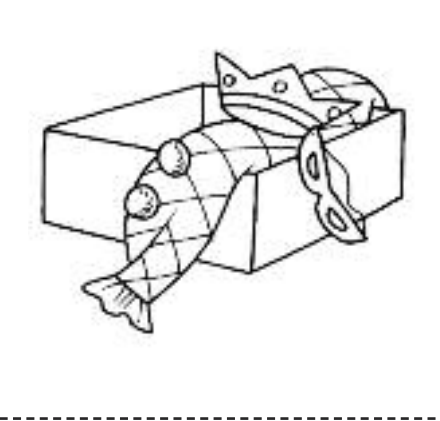
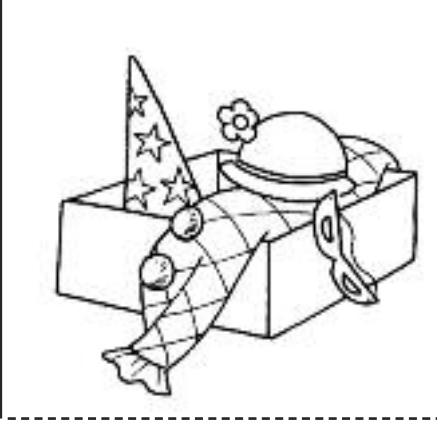
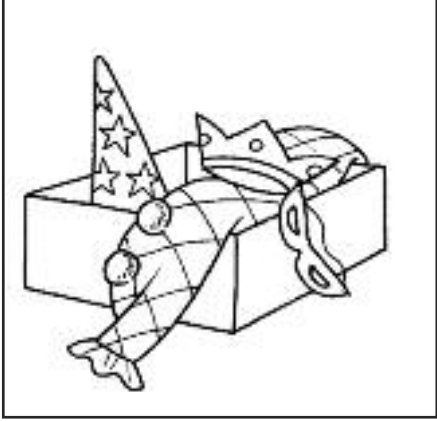

- Colorear la estantería que tiene muchos cuentos y rodear la caja que tiene pocas pinturas.

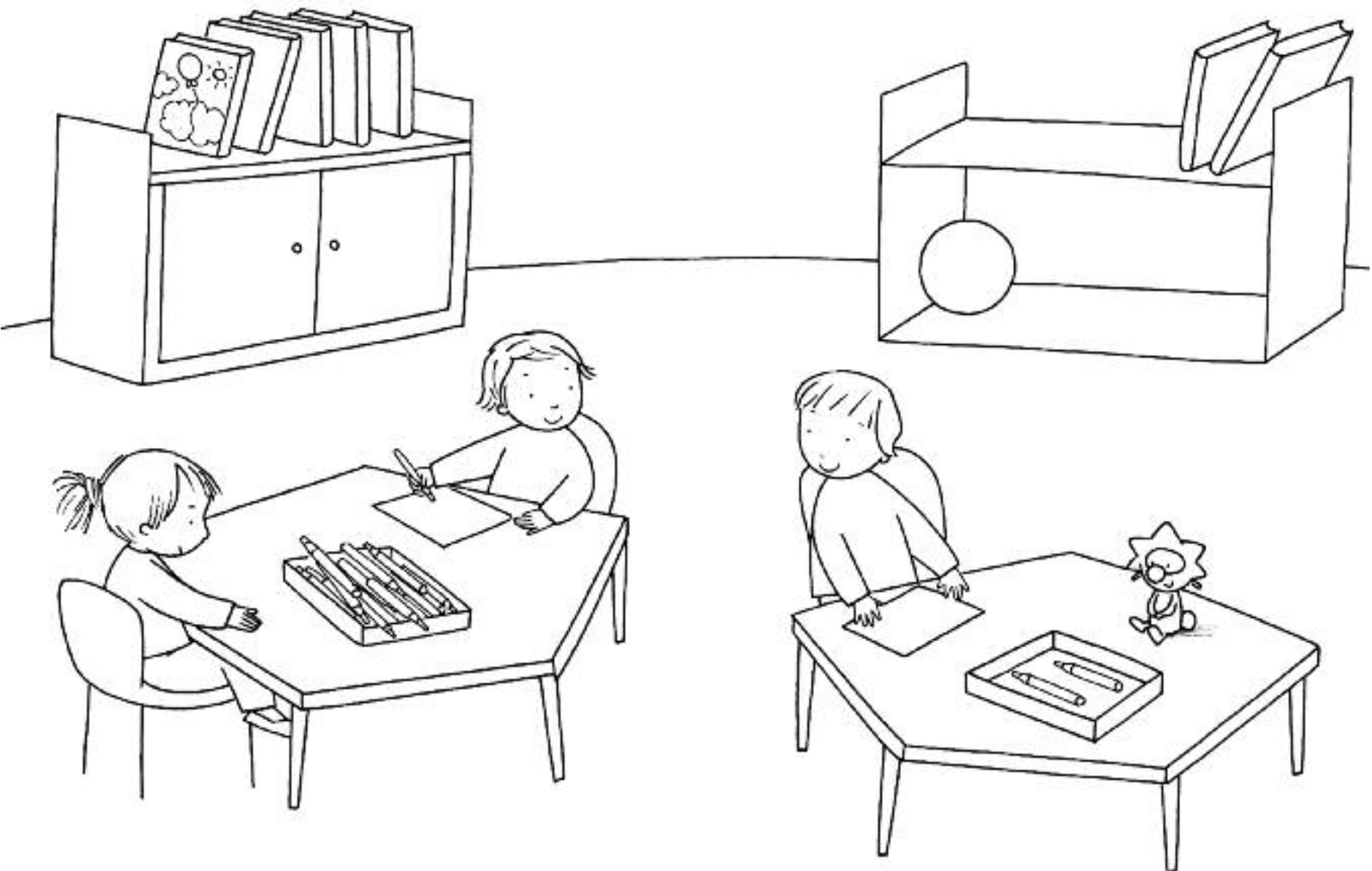

- Repasar y completar las grafías del 2.
- Dibujar dos caminos diferentes que lleguen al colegio.

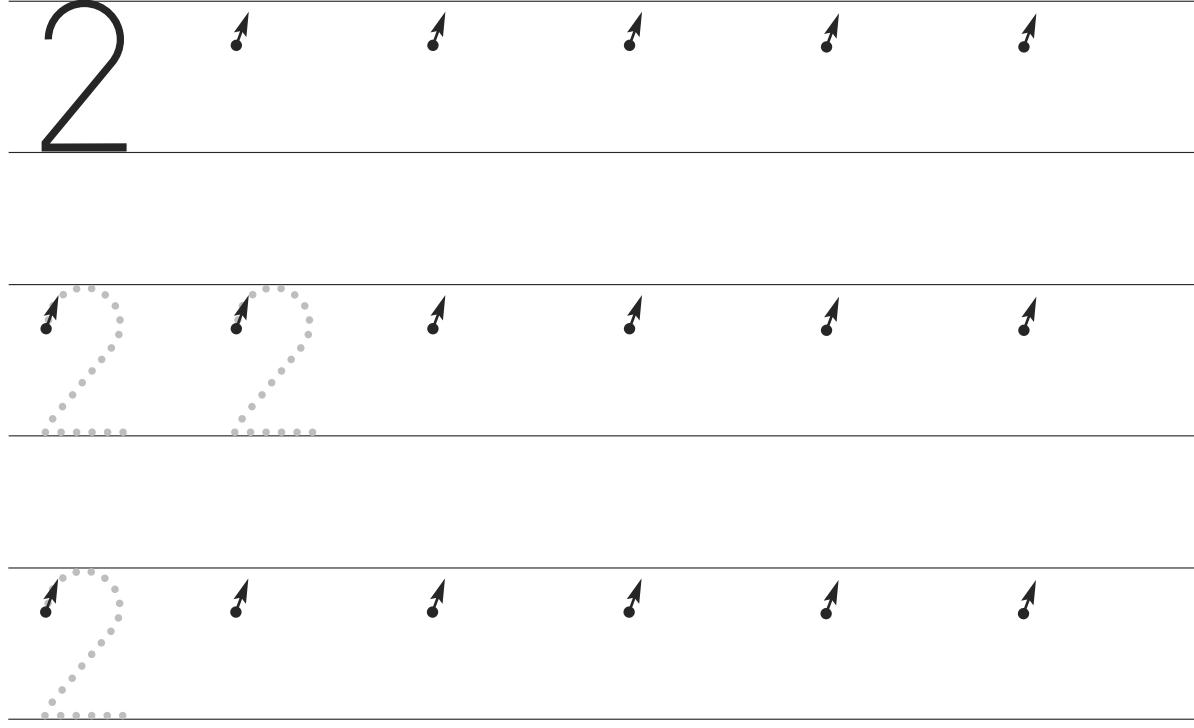
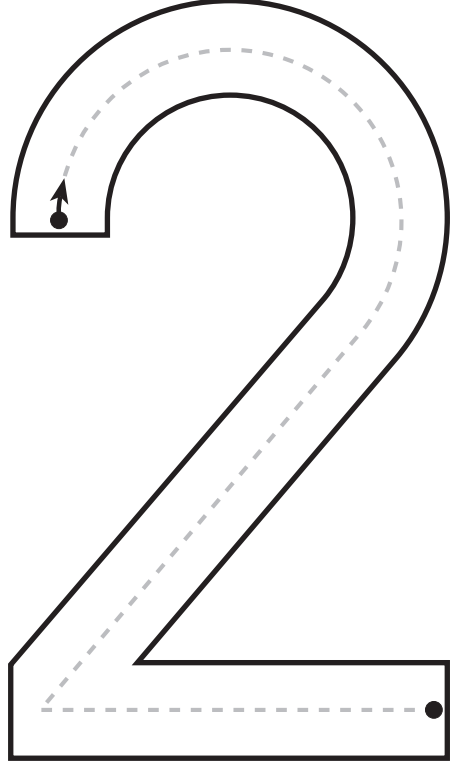



UNIDAD 1

- Completar las figuras y colorearlas.

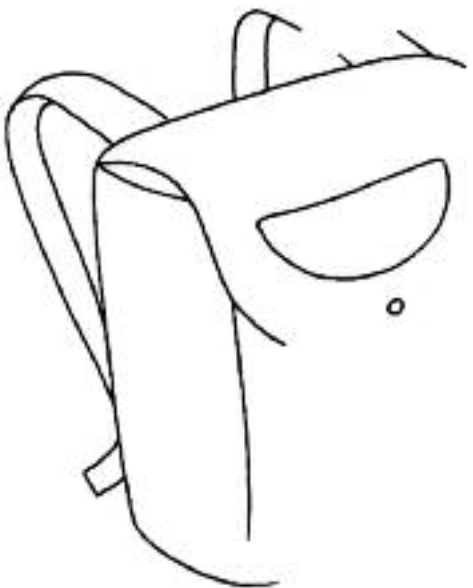



- Colorear los elementos que son más grandes que el colemiú y rodear los que son más pequeños.

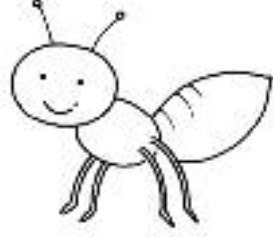
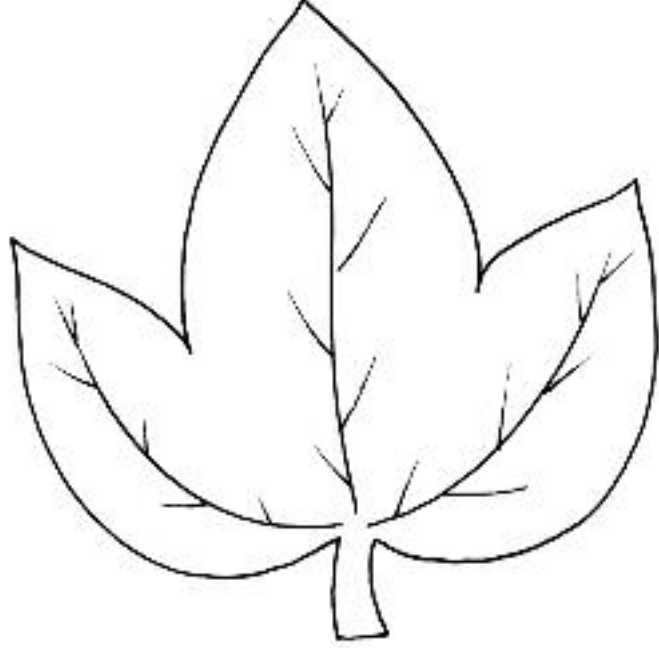
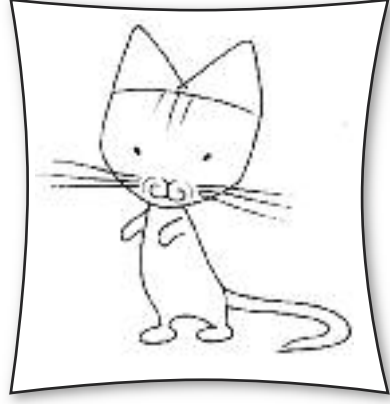



- Seguir las líneas y dibujar cada una de las figuras en el lugar que corresponde.

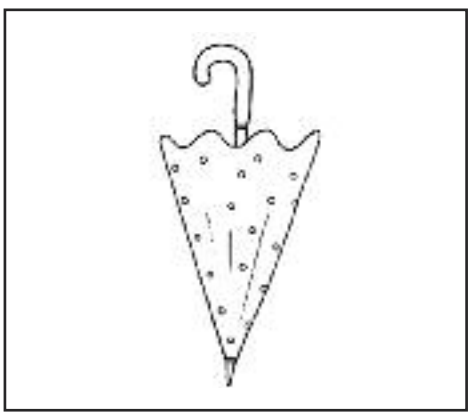
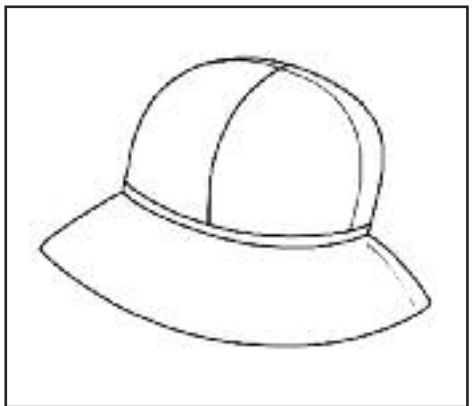
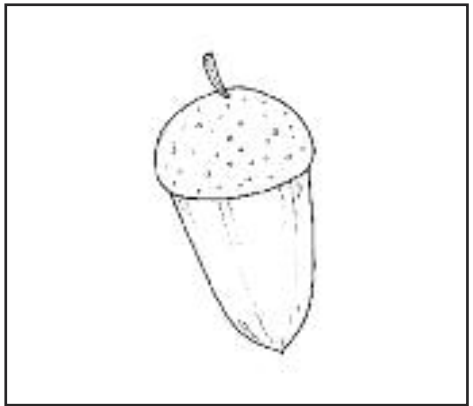
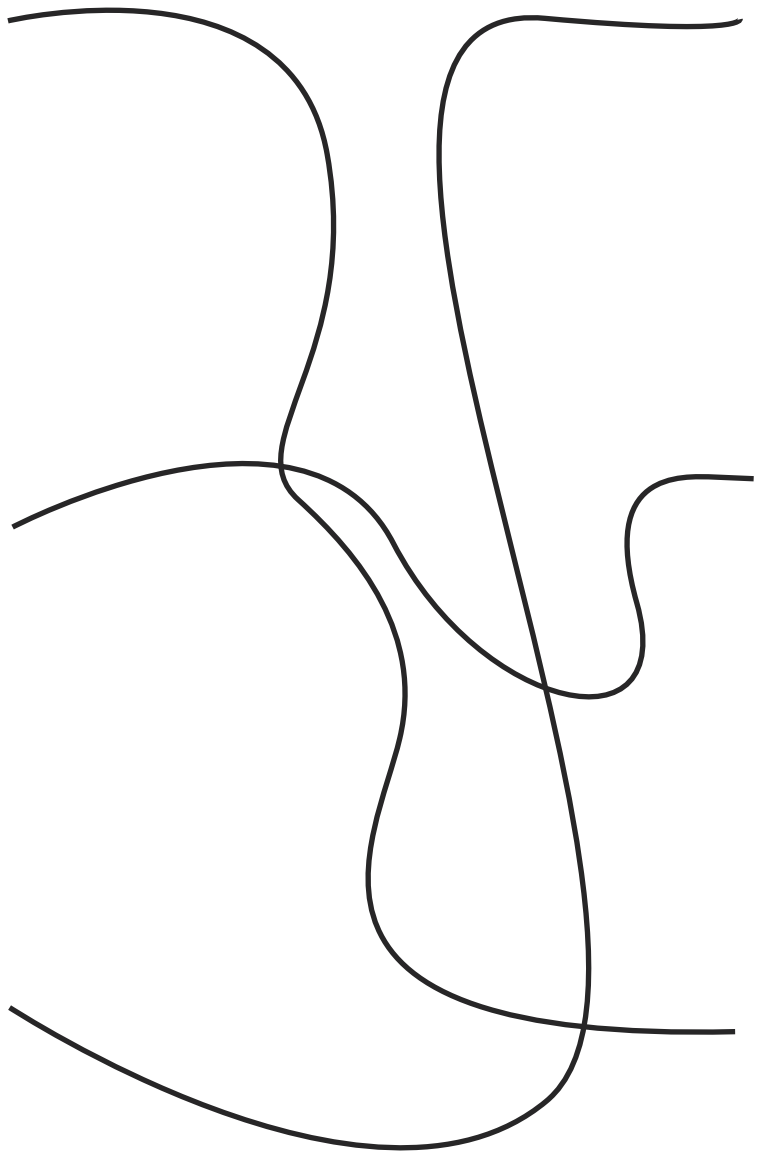
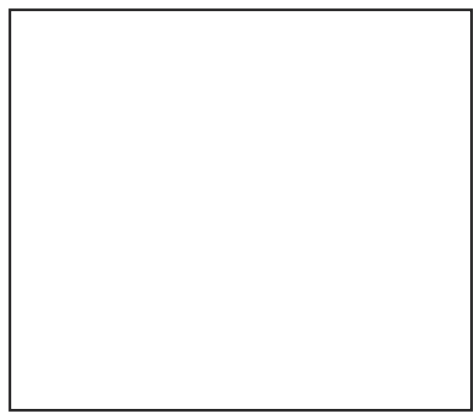



- Repasar y completar las grafías del 3.
- Pegar tres hojas de otoño.

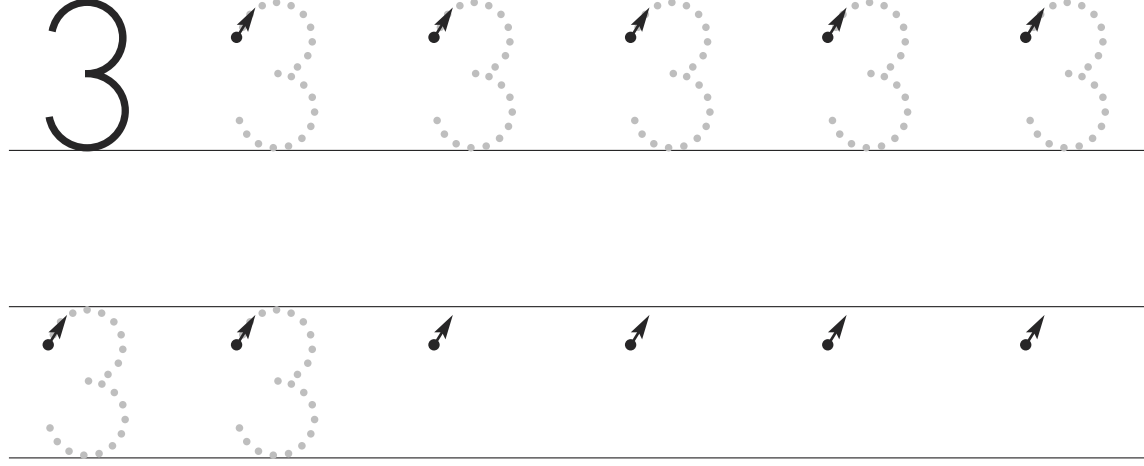
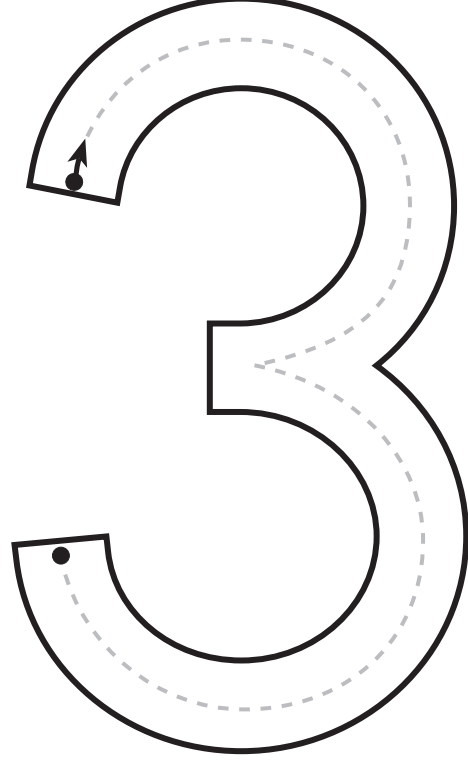
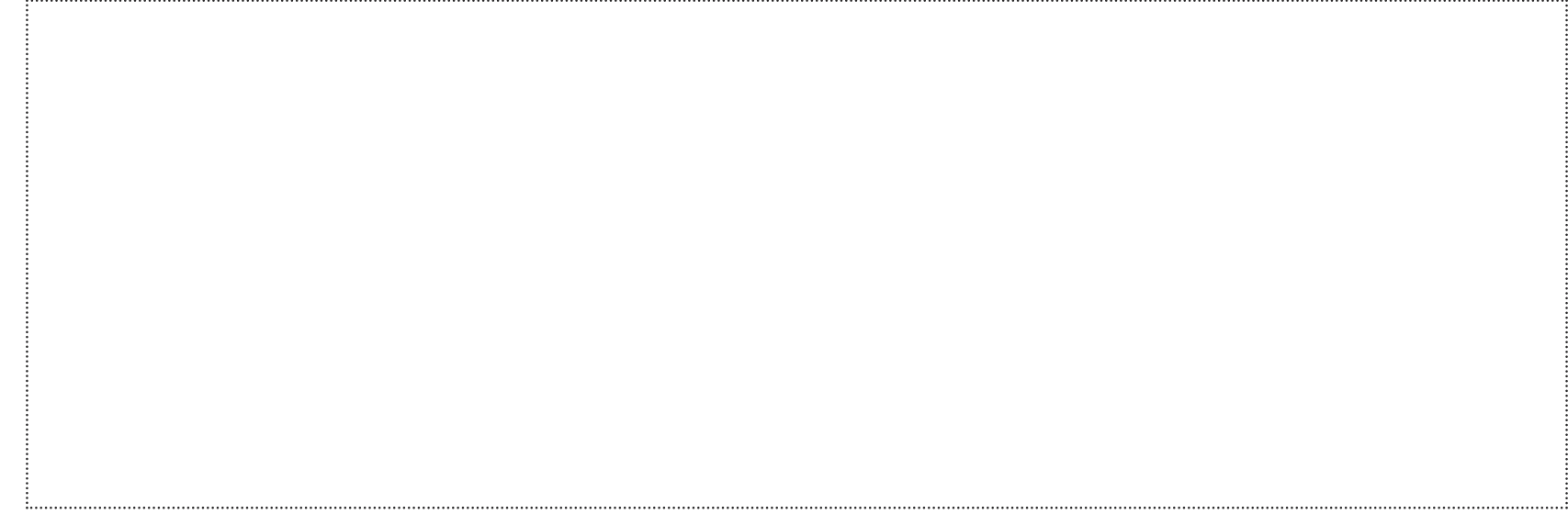

- Dibujar algunos sapos en la charca.
- Colorear todos los sapos.

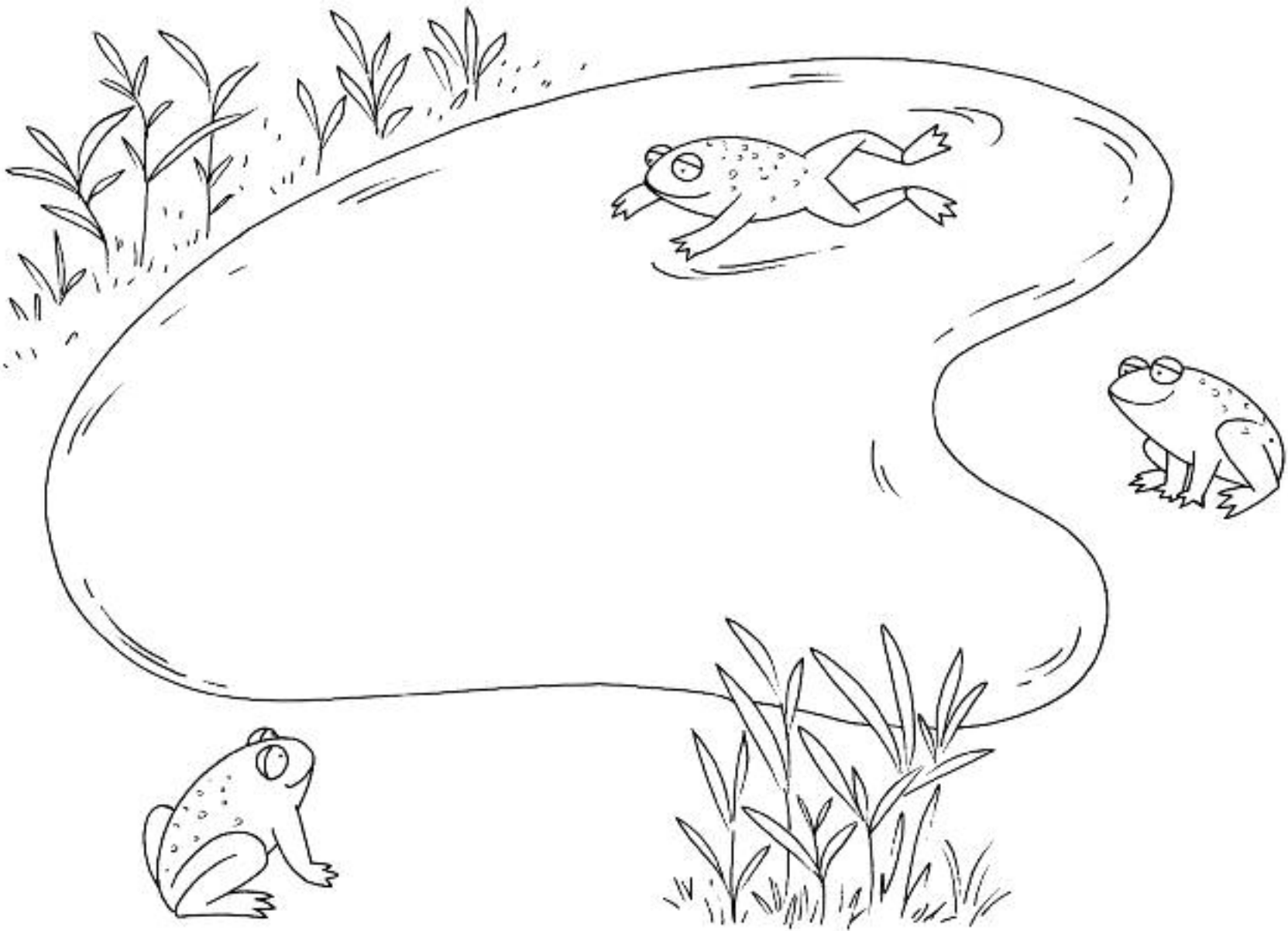



- Tachar las figuras que no son rectángulos. Colorear los rectángulos que son grandes.

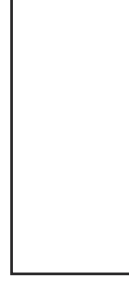
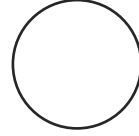
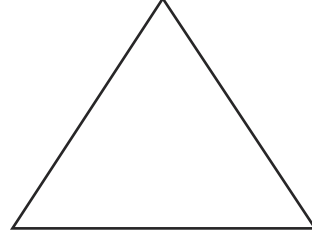
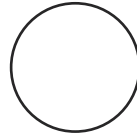
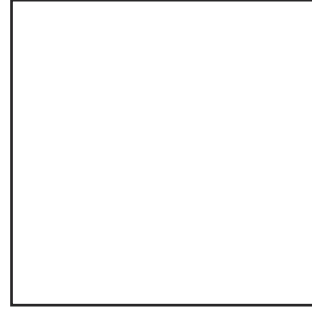
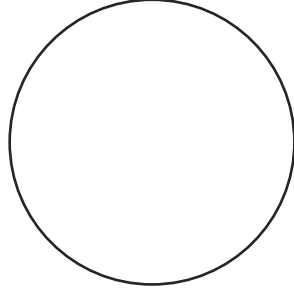
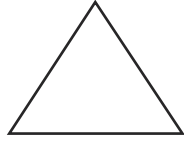



UNIDAD 2

- Repasar los números.
- Unir cada número con la imagen correspondiente.

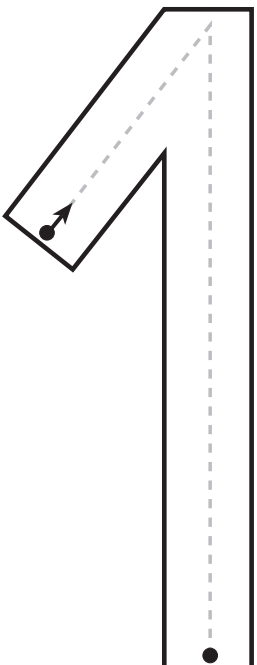
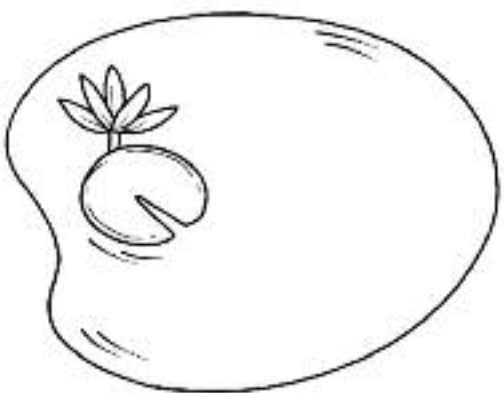
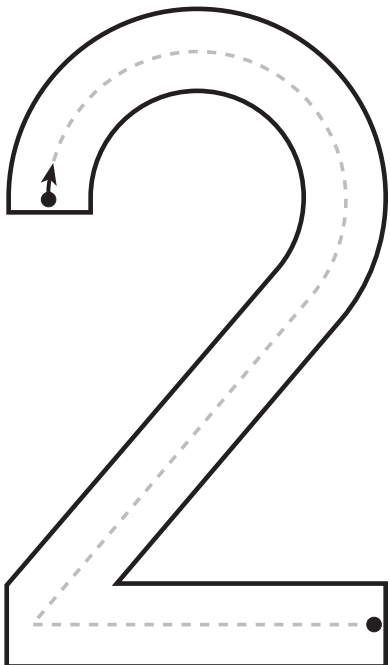
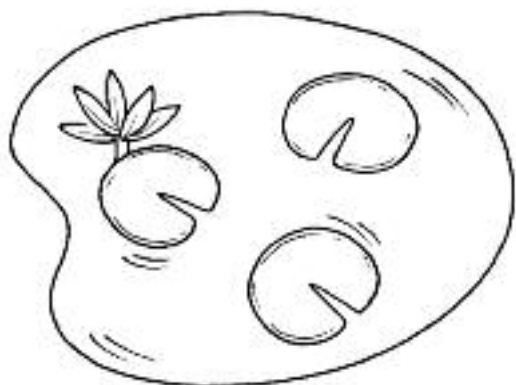
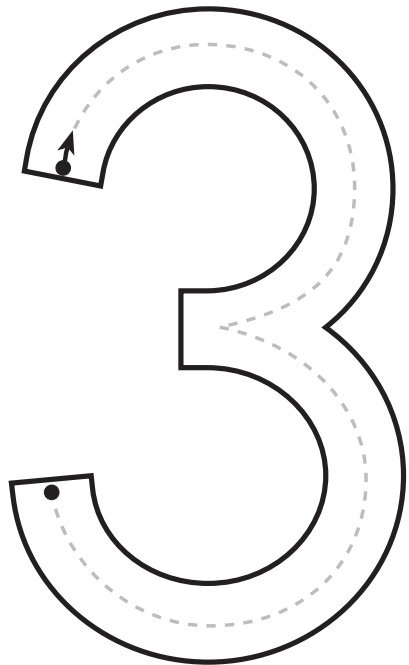



- Colorear los elementos que tienen forma de esfera.
- Imaginar para qué personas puede ser cada regalo y dibujarlas.

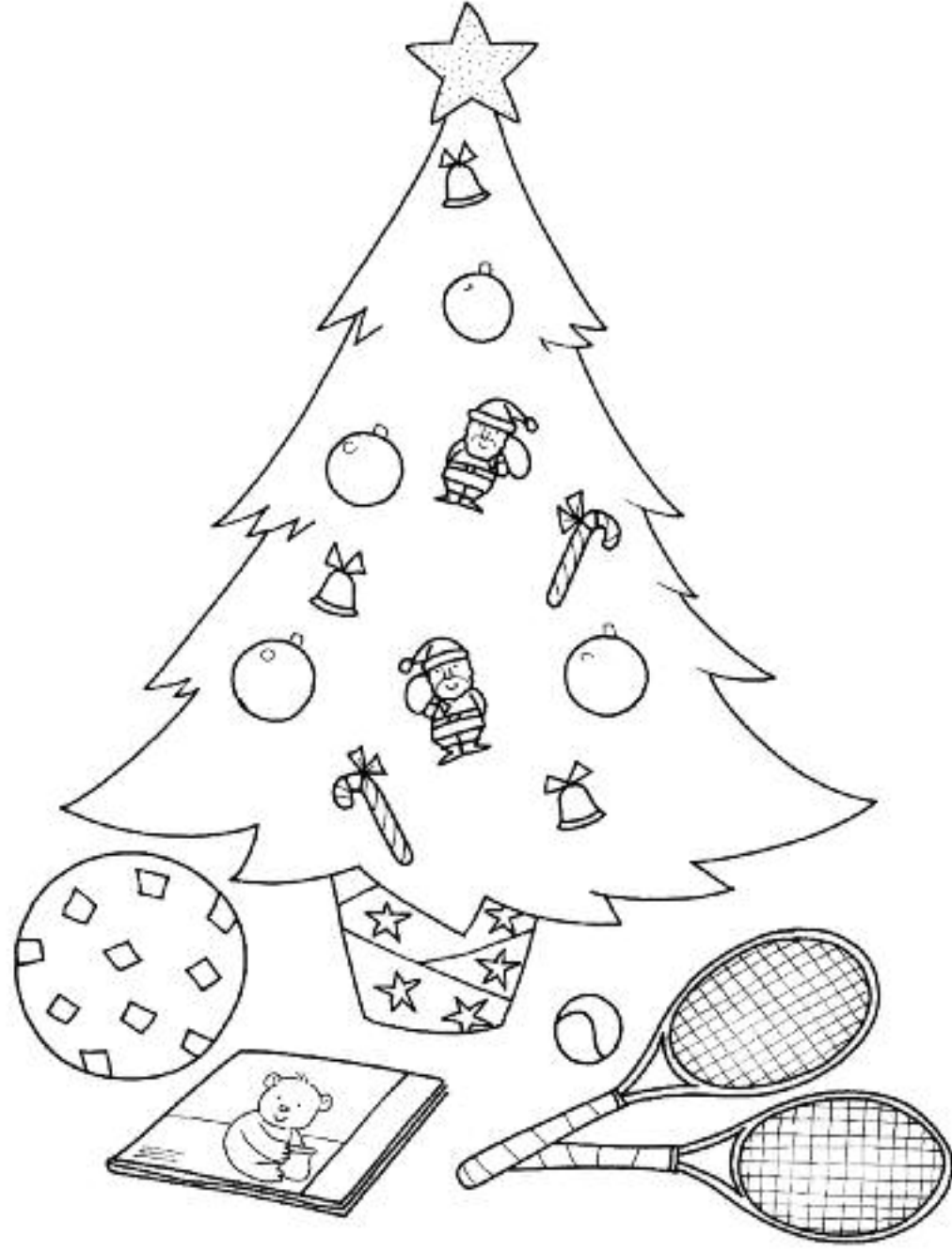



UNIDAD 3

- Decorar el cántaro que está lleno y pegar un gomet en el que está vacío.
- Marcar las líneas rectas de azul y las líneas curvas de rojo.

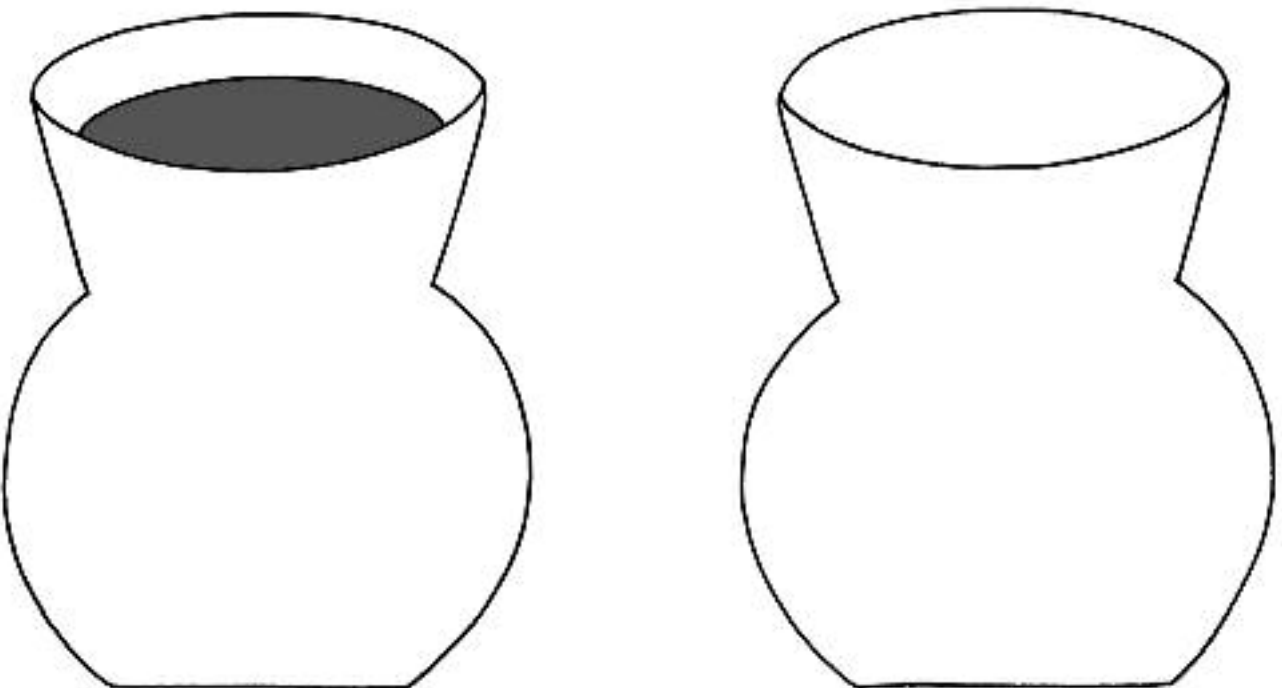

- Colorear al pastorcillo que va el primero y rodear al que va el último.
- Dibujar un animal en el que no lleva ninguna oveja.



- Completar los elementos que faltan en la tarjeta de Navidad siguiendo el modelo.

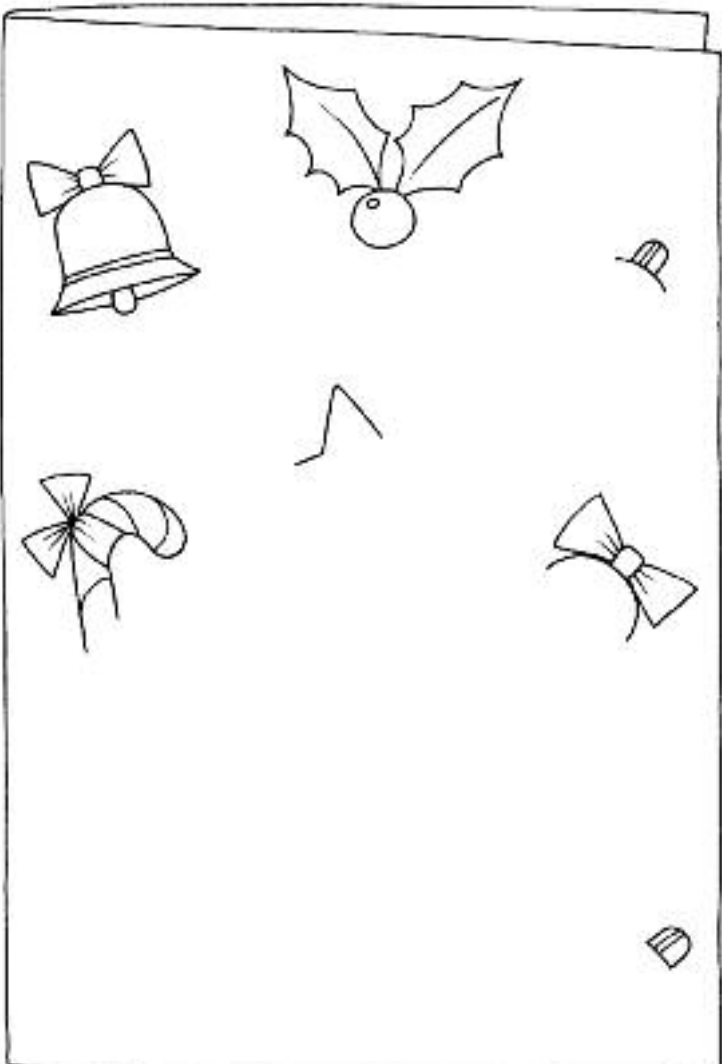



- Dibujar lo que puede contener cada paquete.

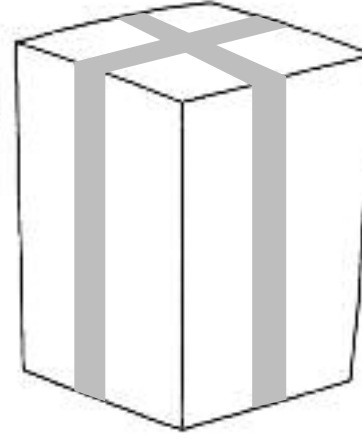
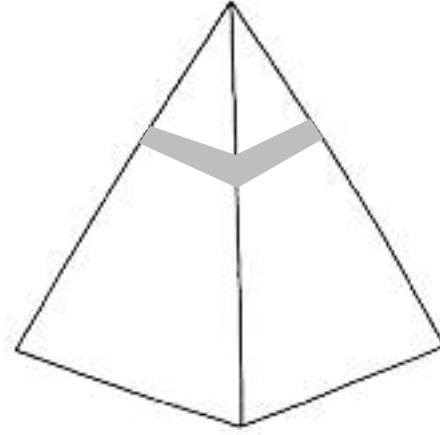
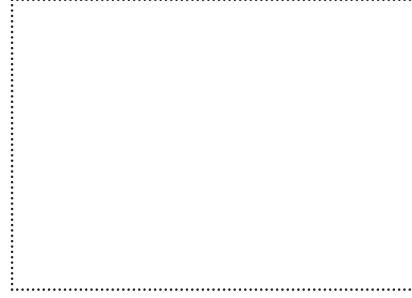
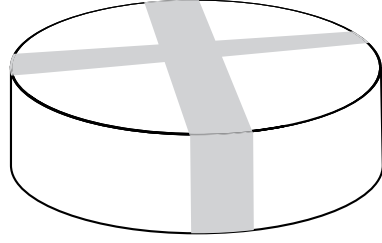
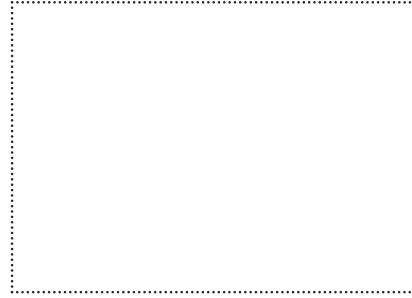
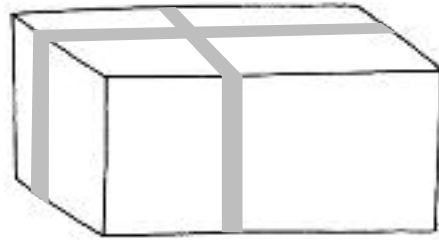

- Repasar el número 4.
- Unir cuatro prendas de invierno con la niña.

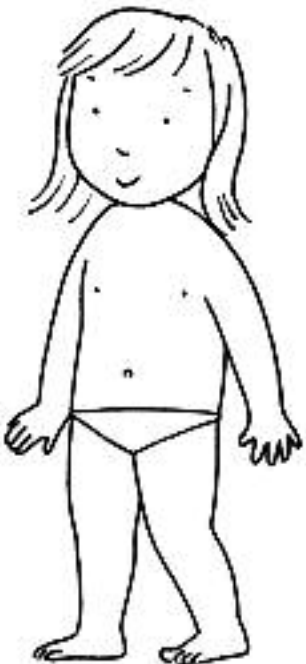
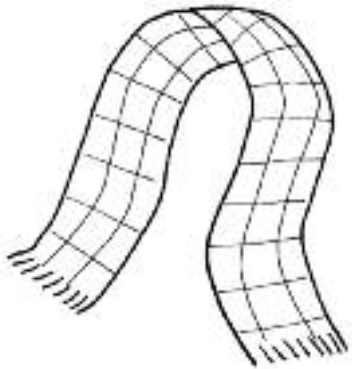
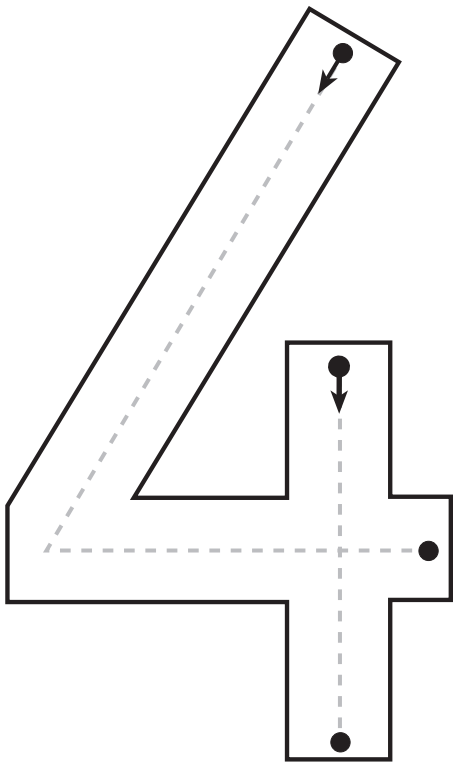

- Dibujar las casas con el tamaño que corresponde en cada casilla para completar la tabla de doble entrada.



- Repasar y completar las grafías del 4.
- Colorear cuatro ventanas del edificio.

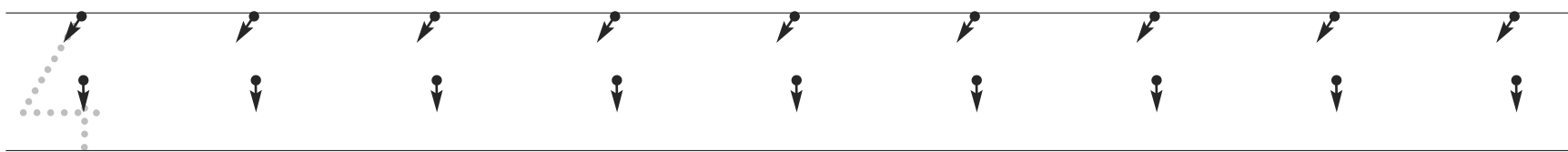
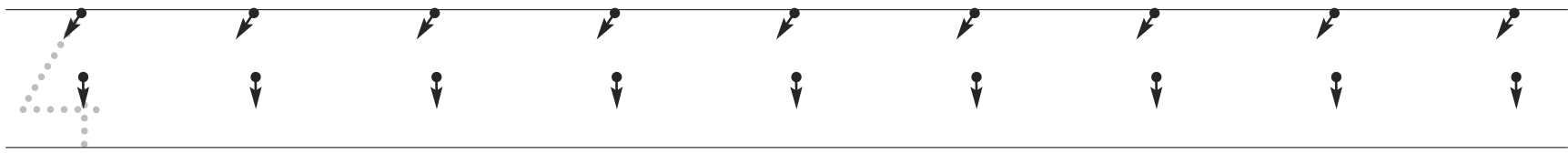
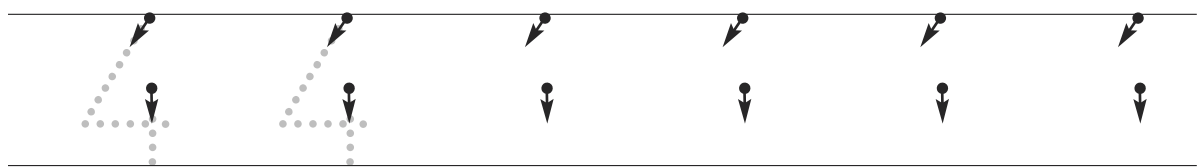
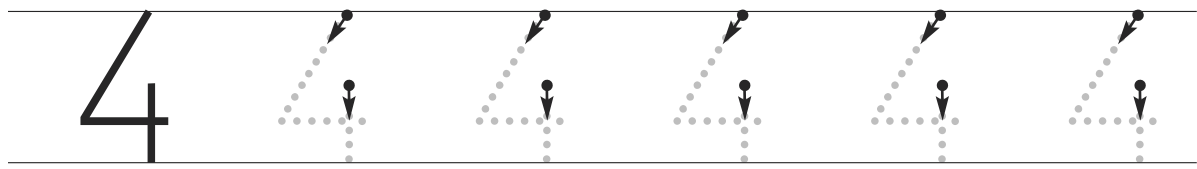

- Tachar en cada fila el objeto que no corresponde.

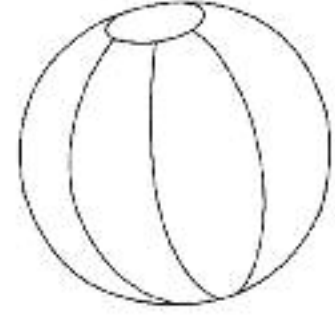
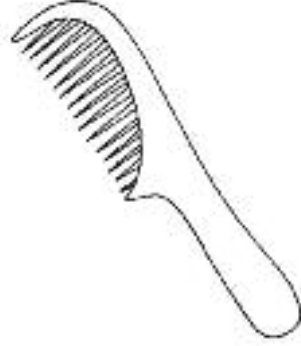
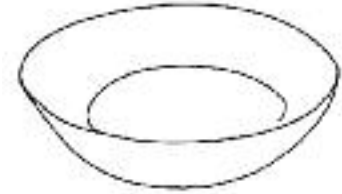
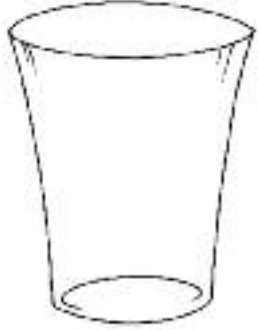
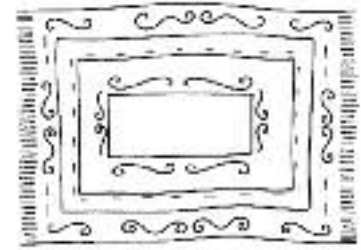
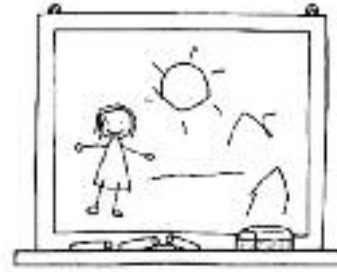

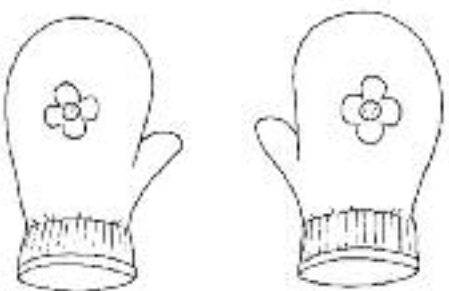
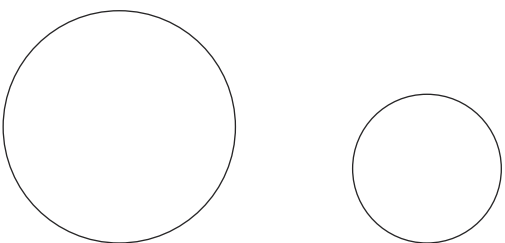
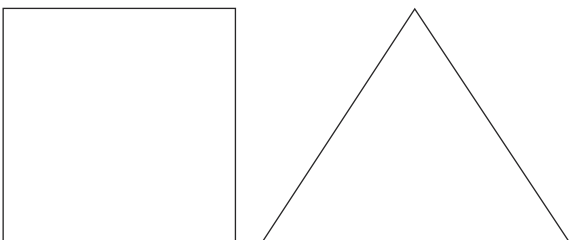

- Agrupar los trineos de cuatro en cuatro y colorear los de cada grupo del mismo color.
- Repasar las grafías del 4.

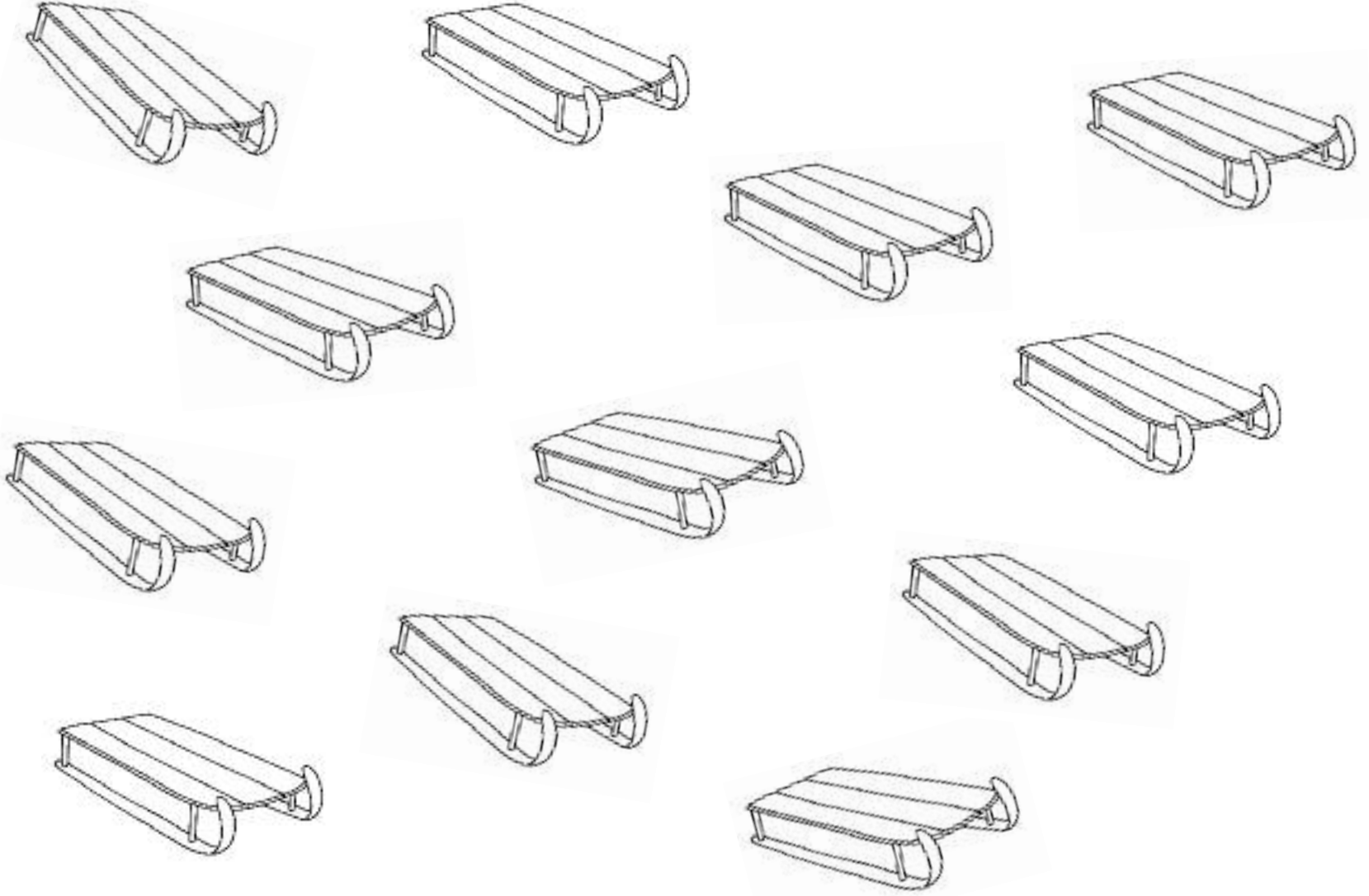
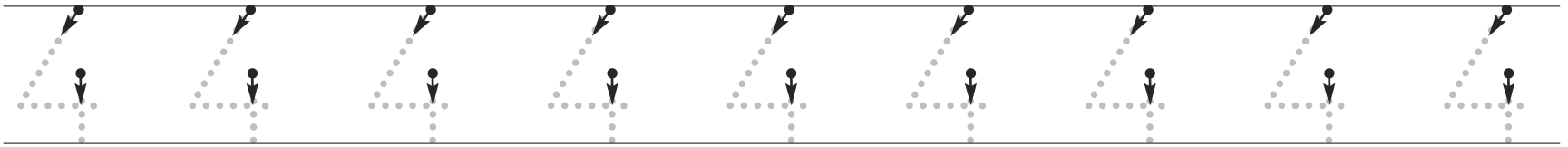

- Dibujar un muñeco de nieve a un lado de la casa y un árbol al otro lado de la casa.



- Repasar los números.
- Unir cada número con la cantidad que representa.

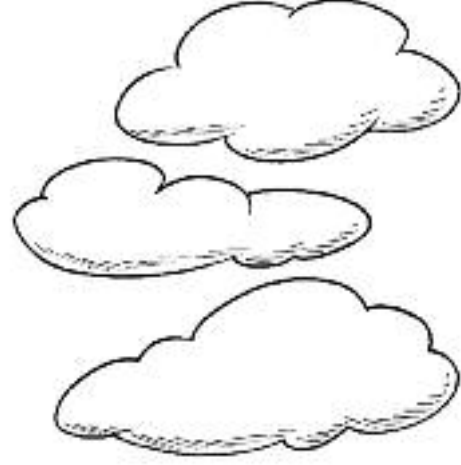
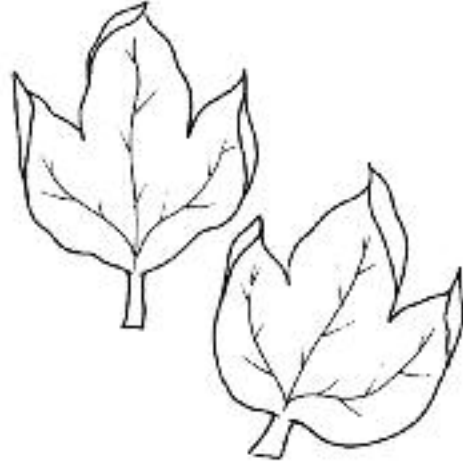
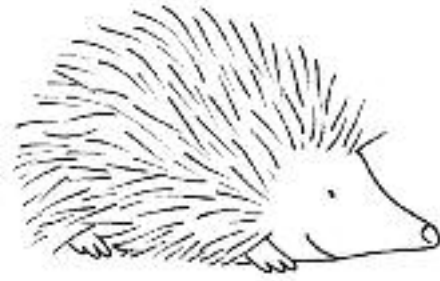
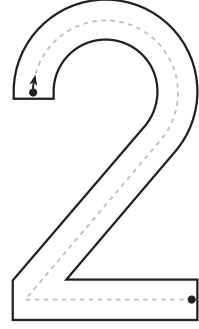
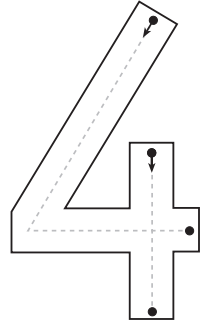
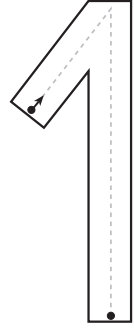



- Repasar las grafías.
- Completar cada grupo con los elementos que faltan.

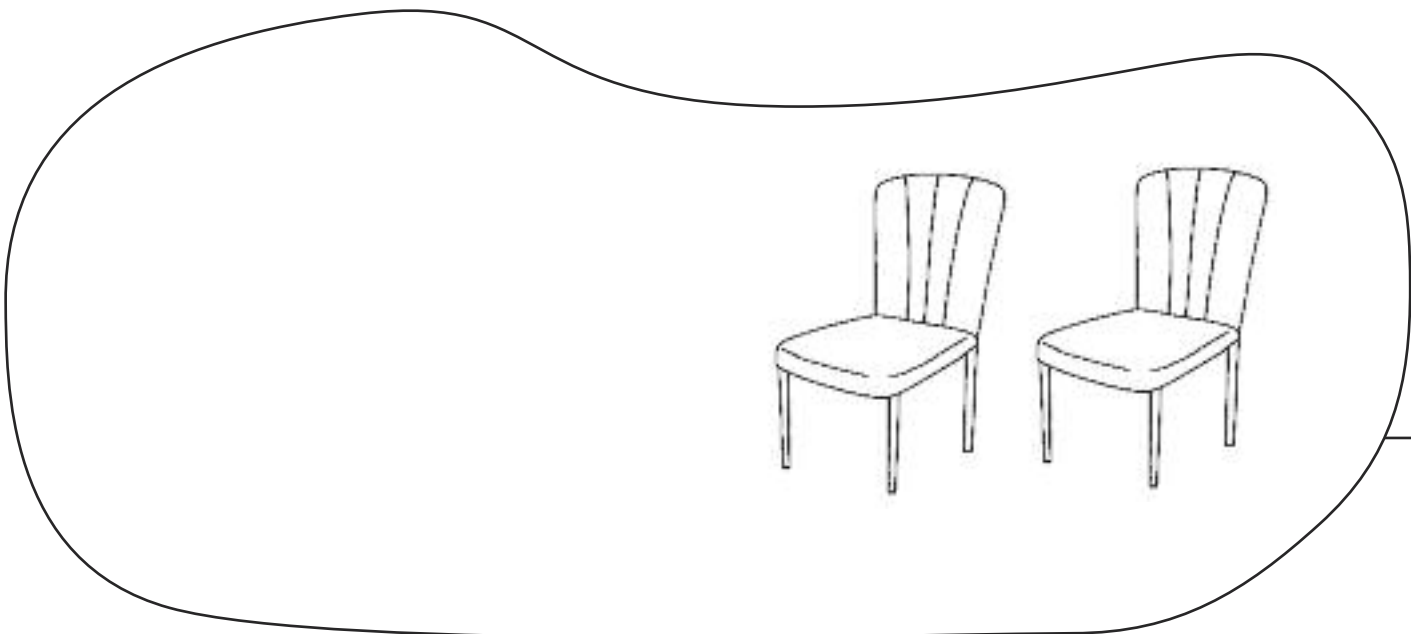
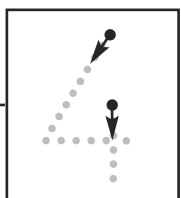
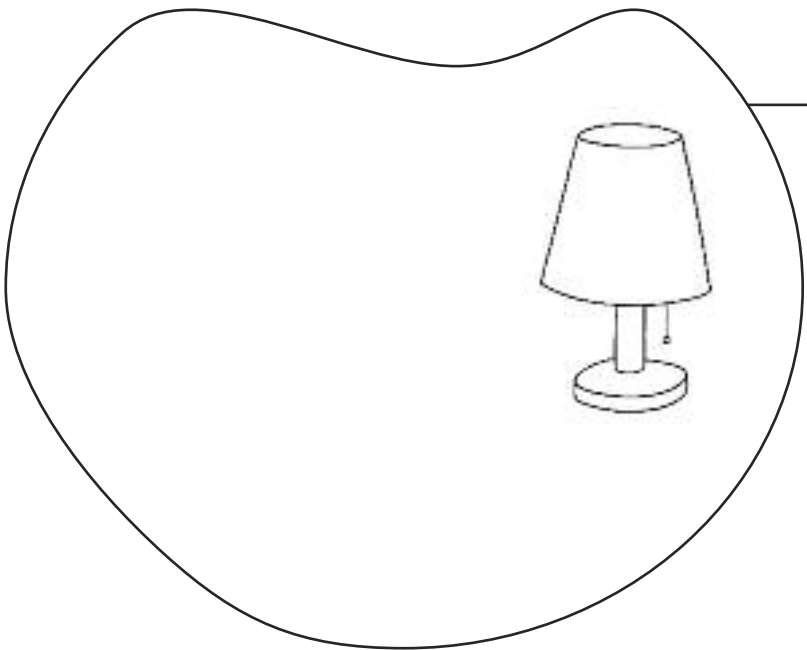
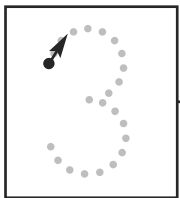
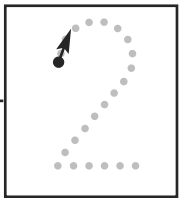
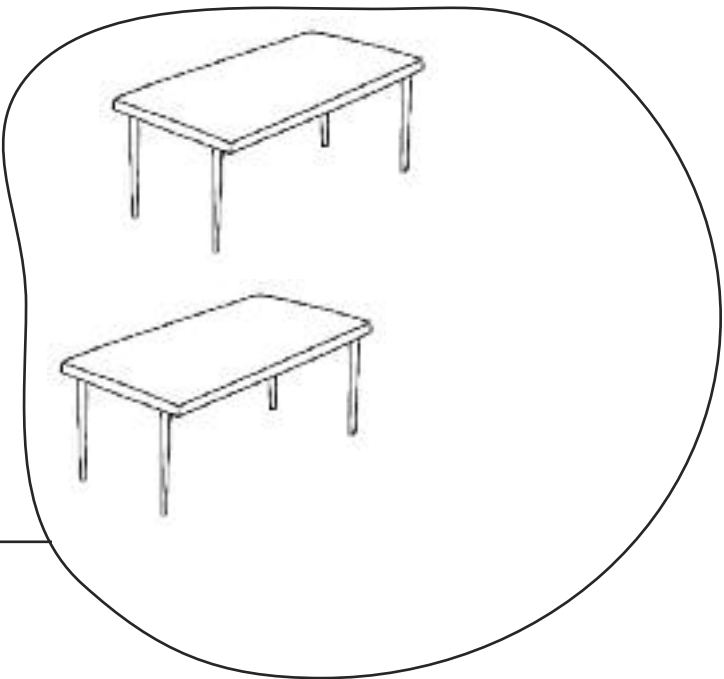

- Colorear de amarillo los espacios con el número 1, de azul los espacios con el número 2, de naranja los espacios con el número 3 y de verde, los del 4.

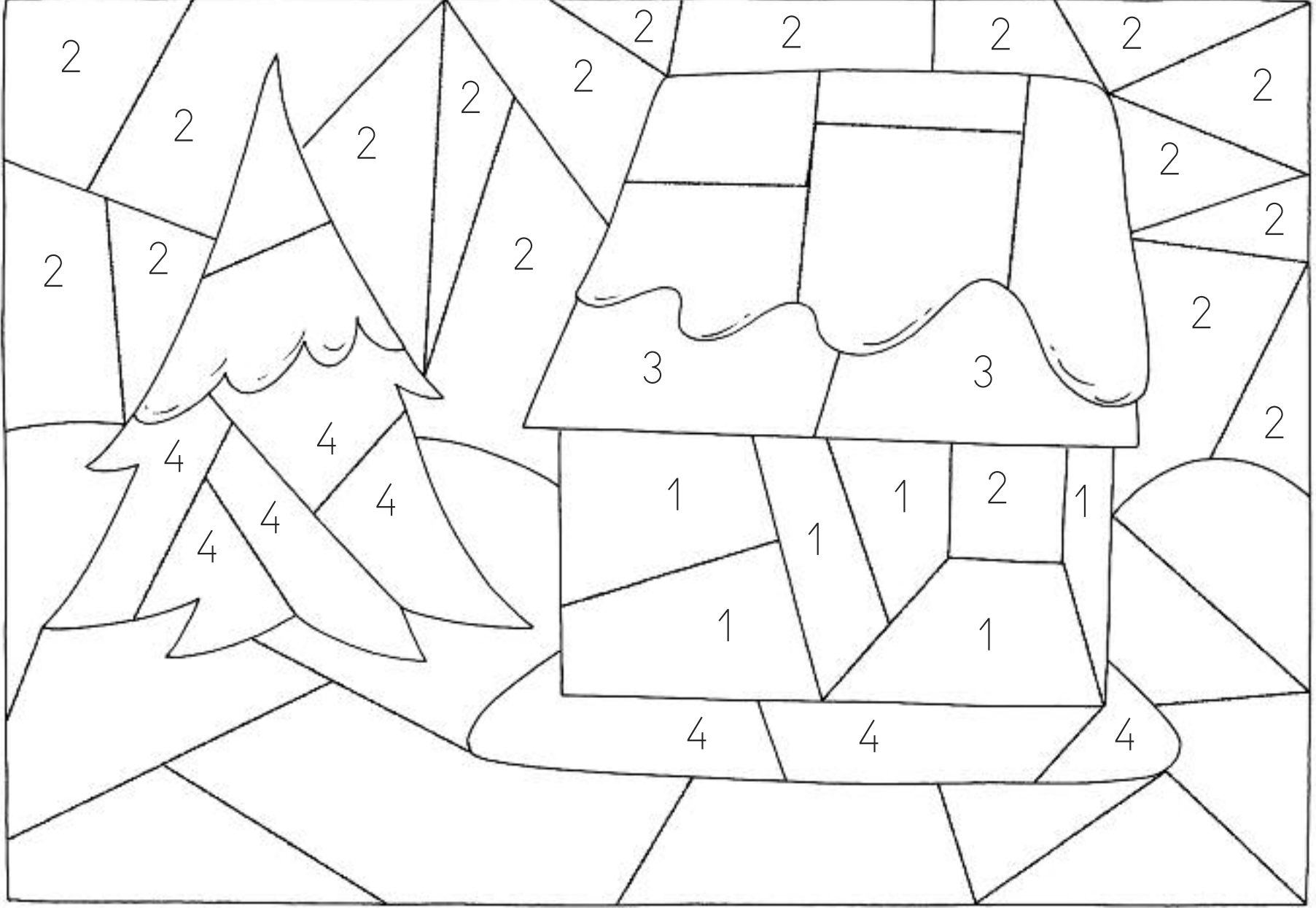

- Recortar los alimentos y pegarlos al lado del animal que los proporciona.
- Colorear el que más guste.

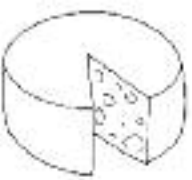
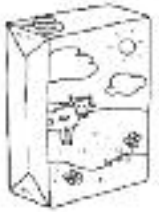
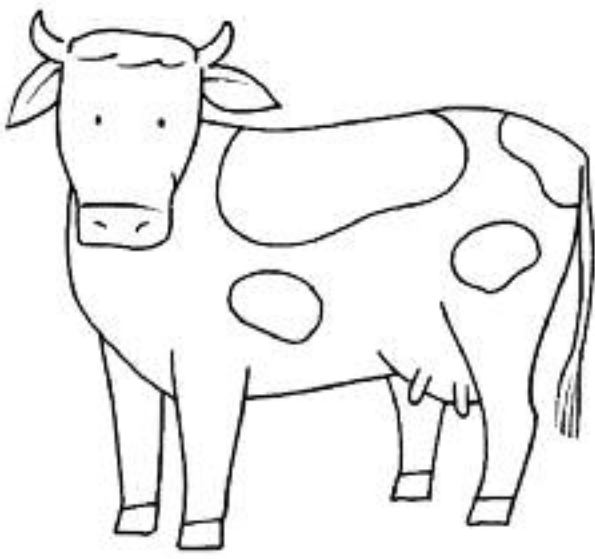
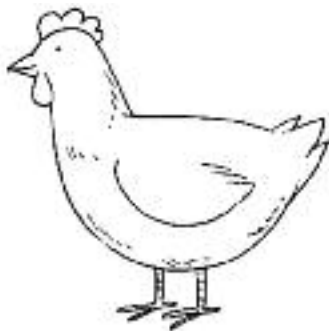
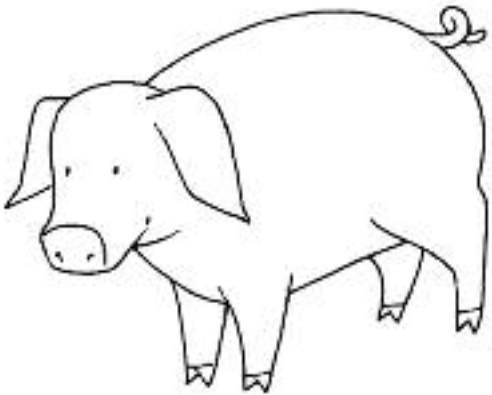

- Escribir los ordinales 1.º, 2.º y 3.º debajo de cada escena según ocurra por la mañana, por la tarde o por la noche.





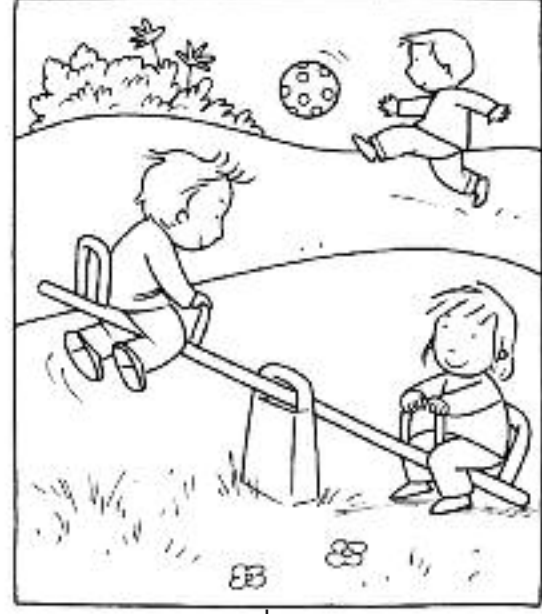

- Colorear el perro que está cerca de la granja y dibujar un pájaro lejos de la granja.

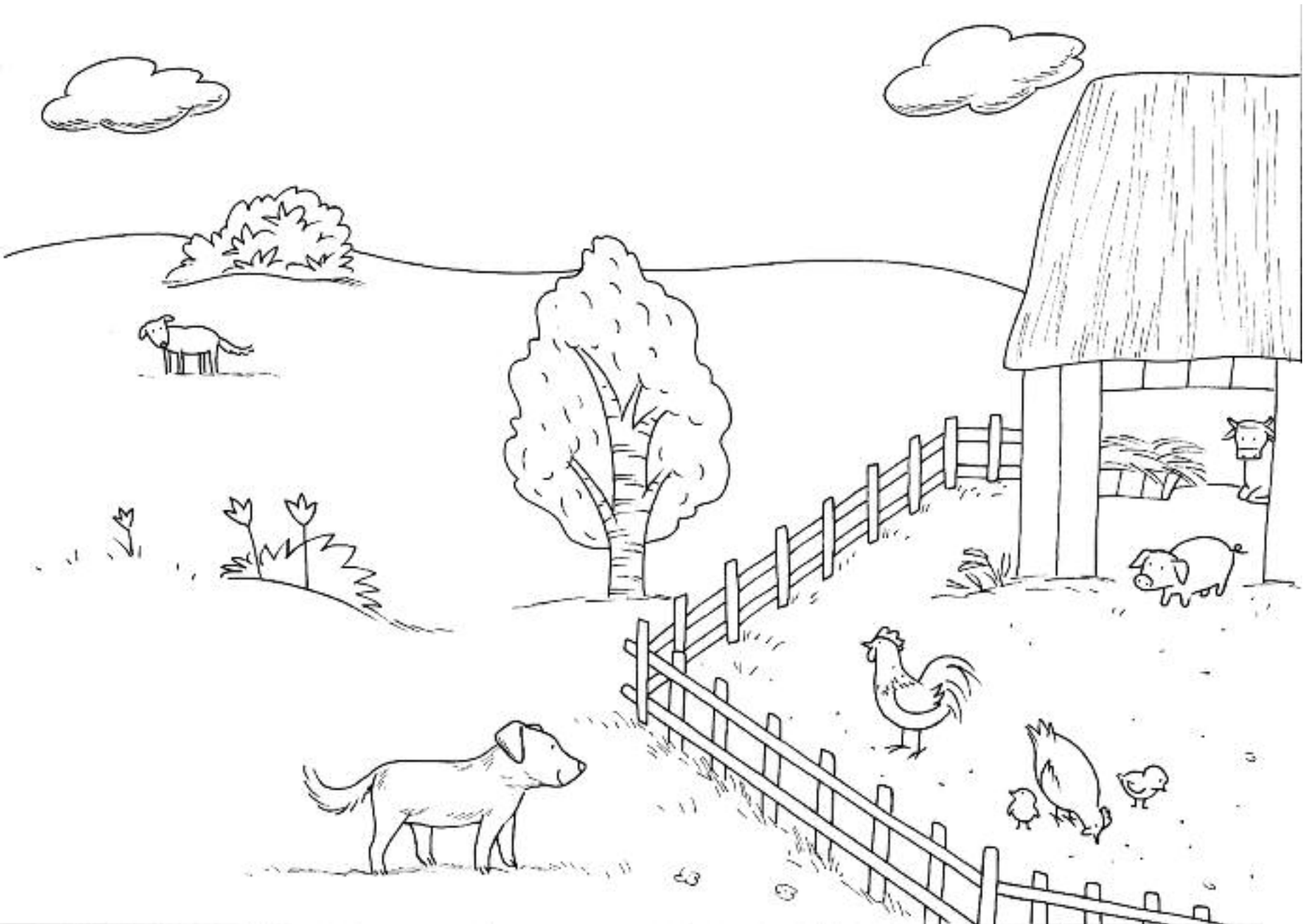



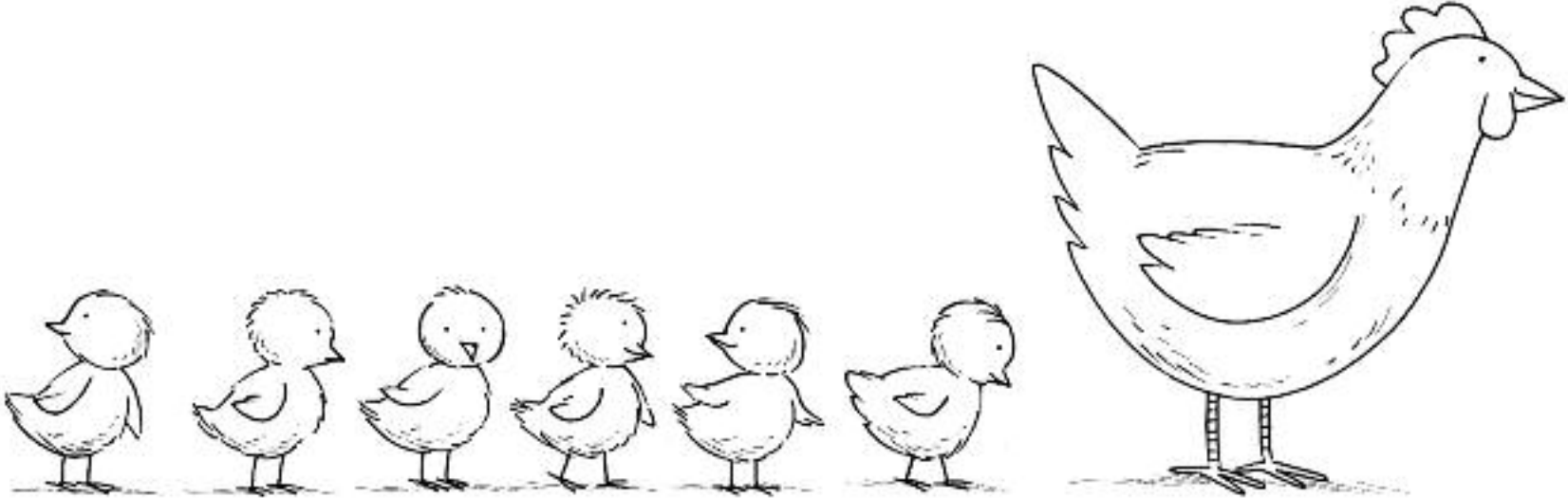
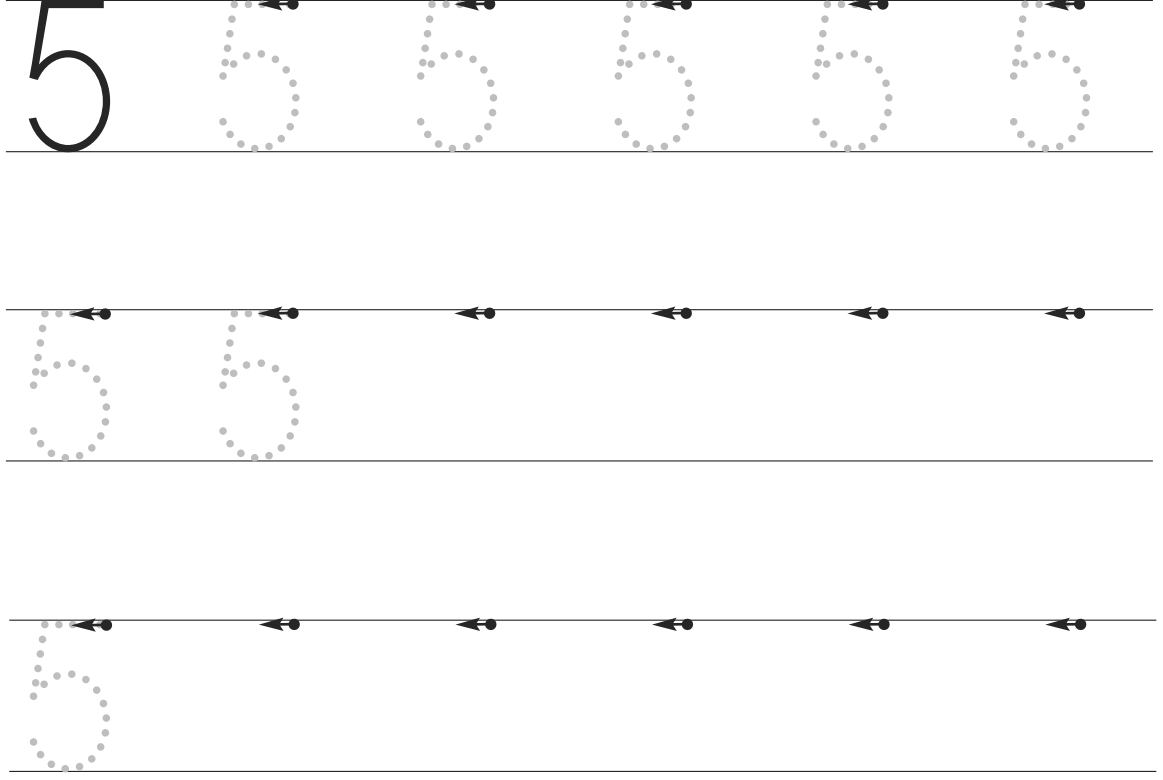
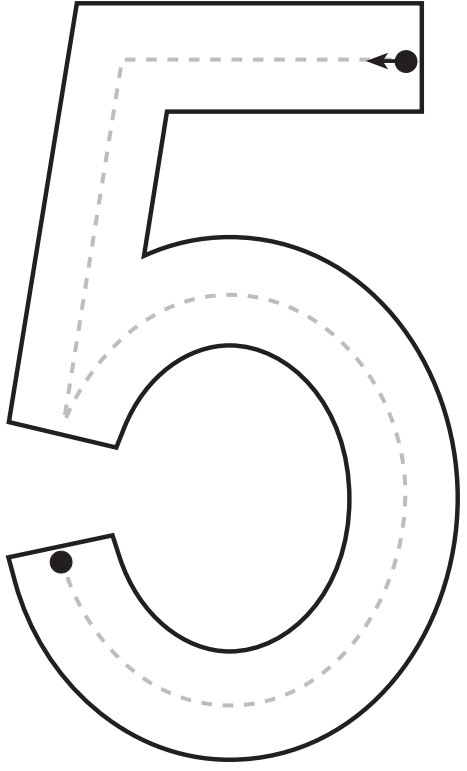

- Repasar y completar las grafías del 5.
- Colorear cinco pollitos.



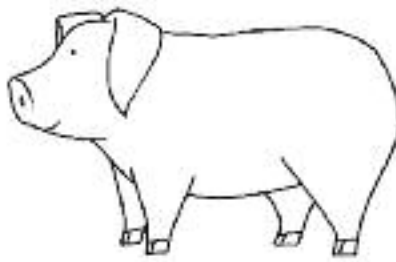
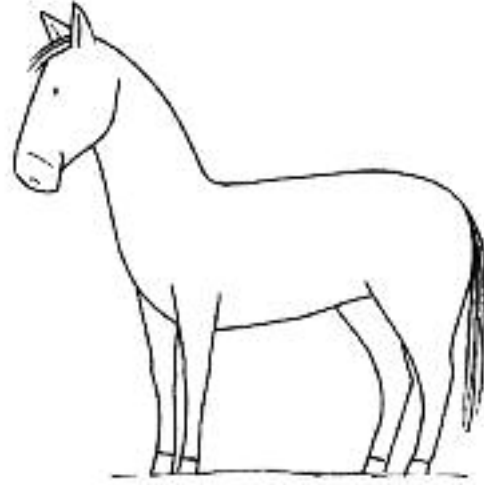

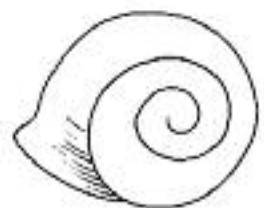
• Unir cada animal con la parte que le falta.



			
---	---	---	---

- Rodear cinco alimentos iguales y unirlos entre sí.
- Colorear los alimentos que suelen tomarse de postre.

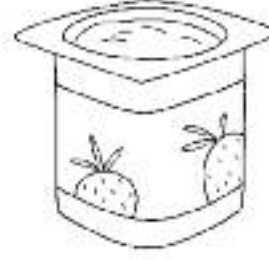



- Dibujar tantos vasos como platos hay en la mesa.

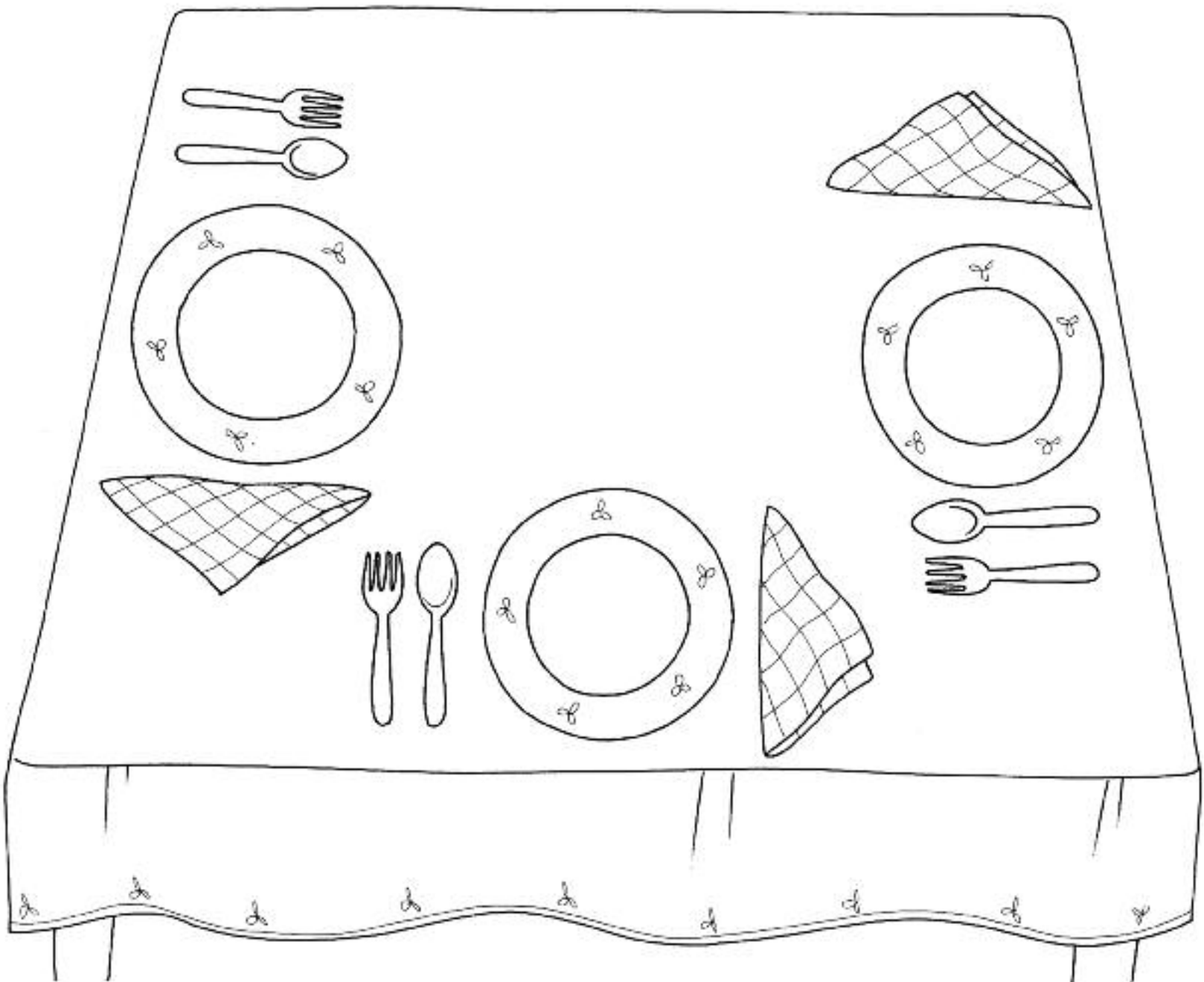

- Escribir el número que corresponde a cada conjunto.

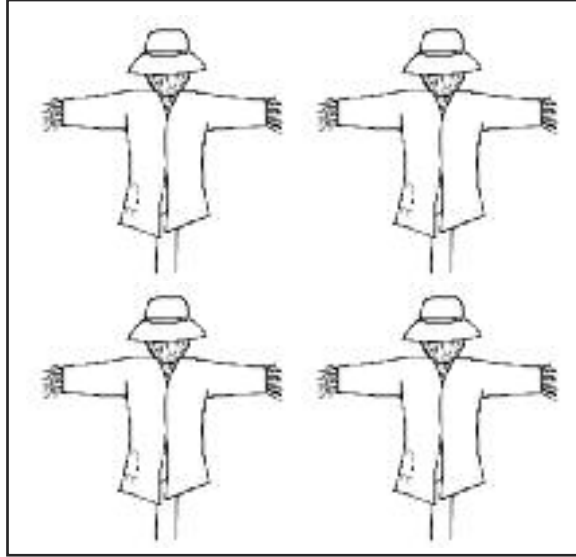

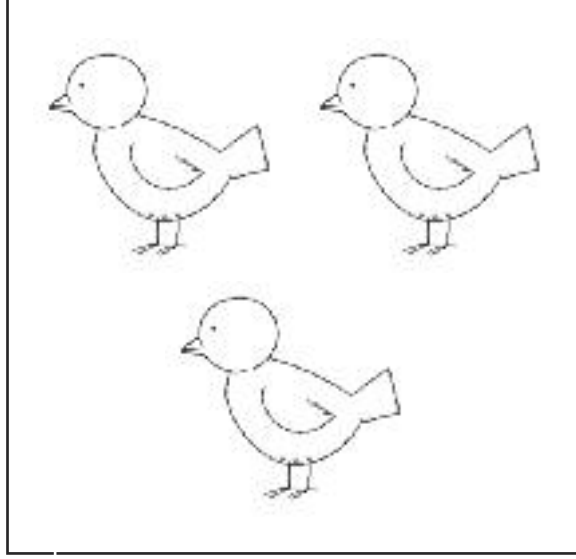

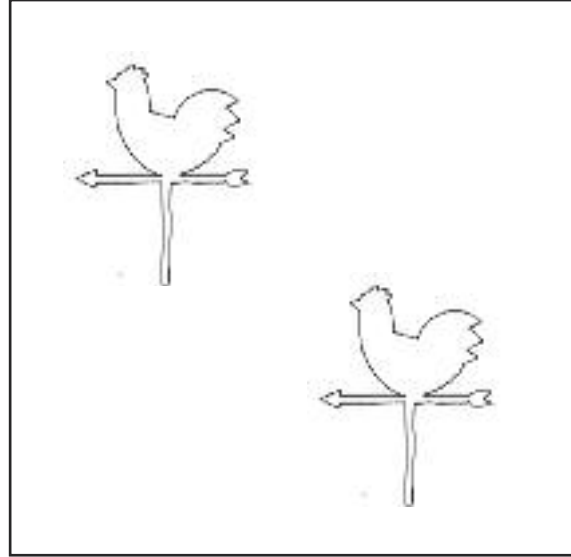

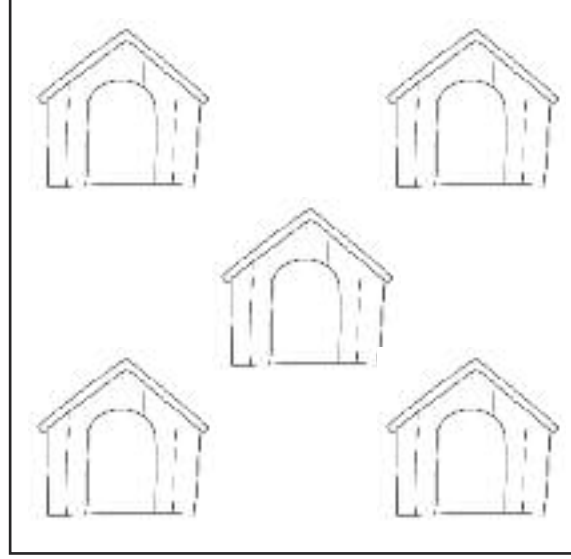



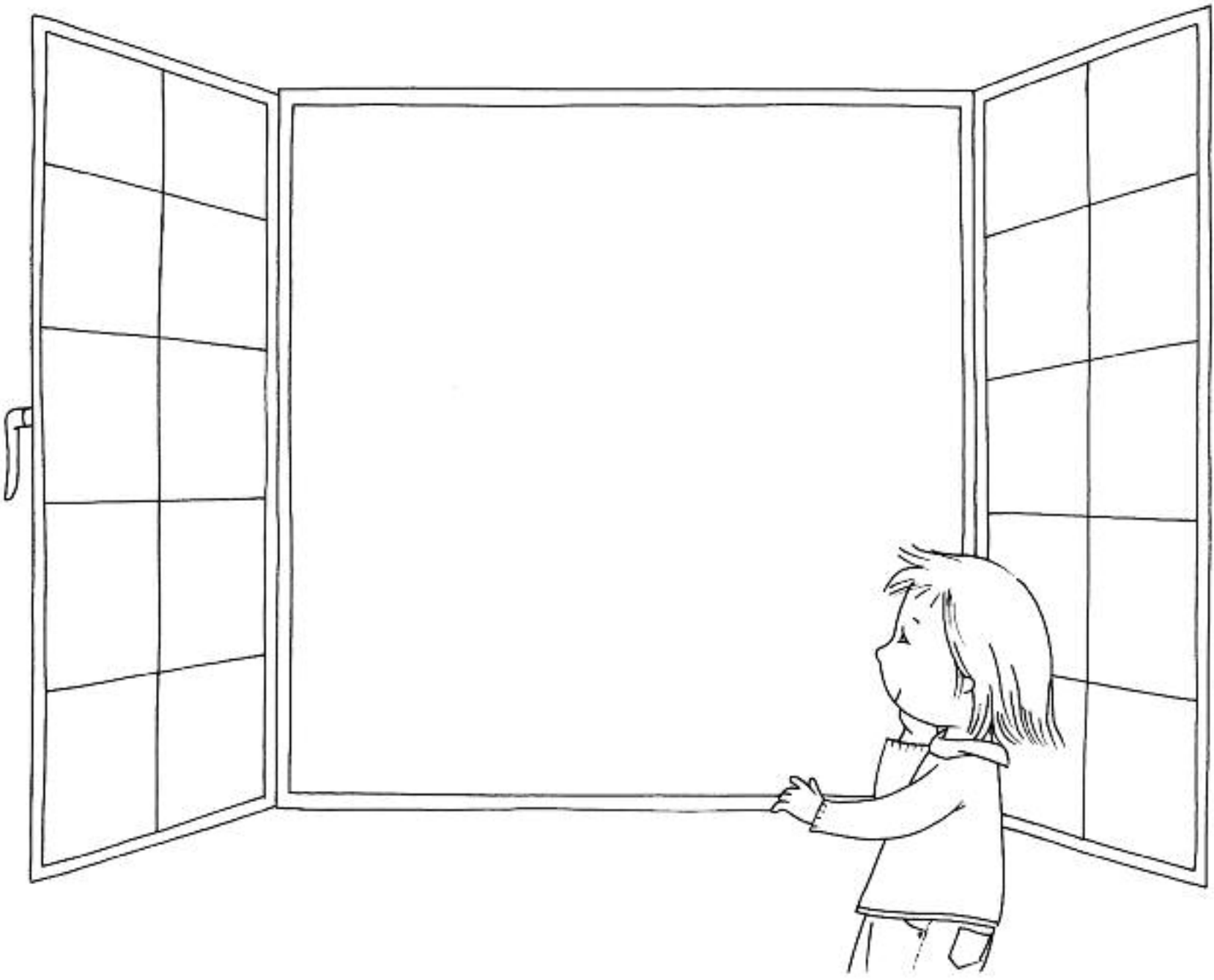

- Dibujar el paisaje que la niña está viendo por la ventana.



- Dibujar la estrella de Lila cuando está de frente.
- Escribir en cada casilla el número de veces que Lila está de frente y de espaldas.

	
---	--

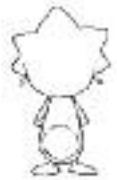
	
--	--

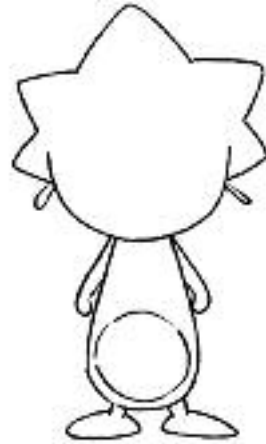
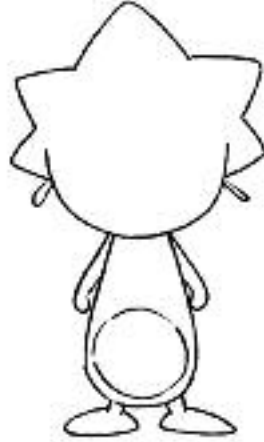
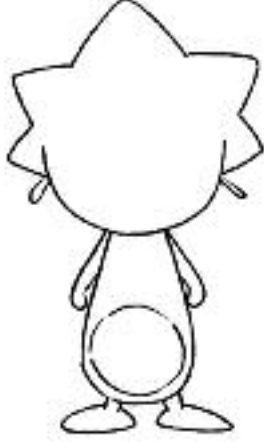
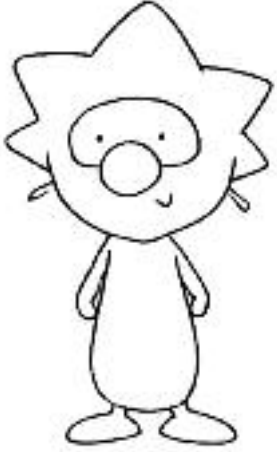
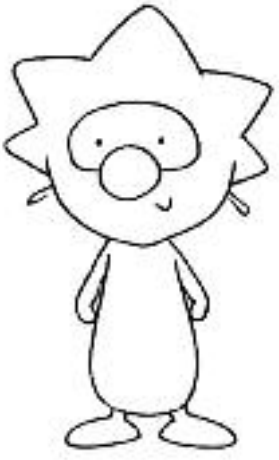



- Colorear las abejas que están alrededor de la colmena.
- Dibujar las abejas necesarias para que haya más en la flor que en el panal.

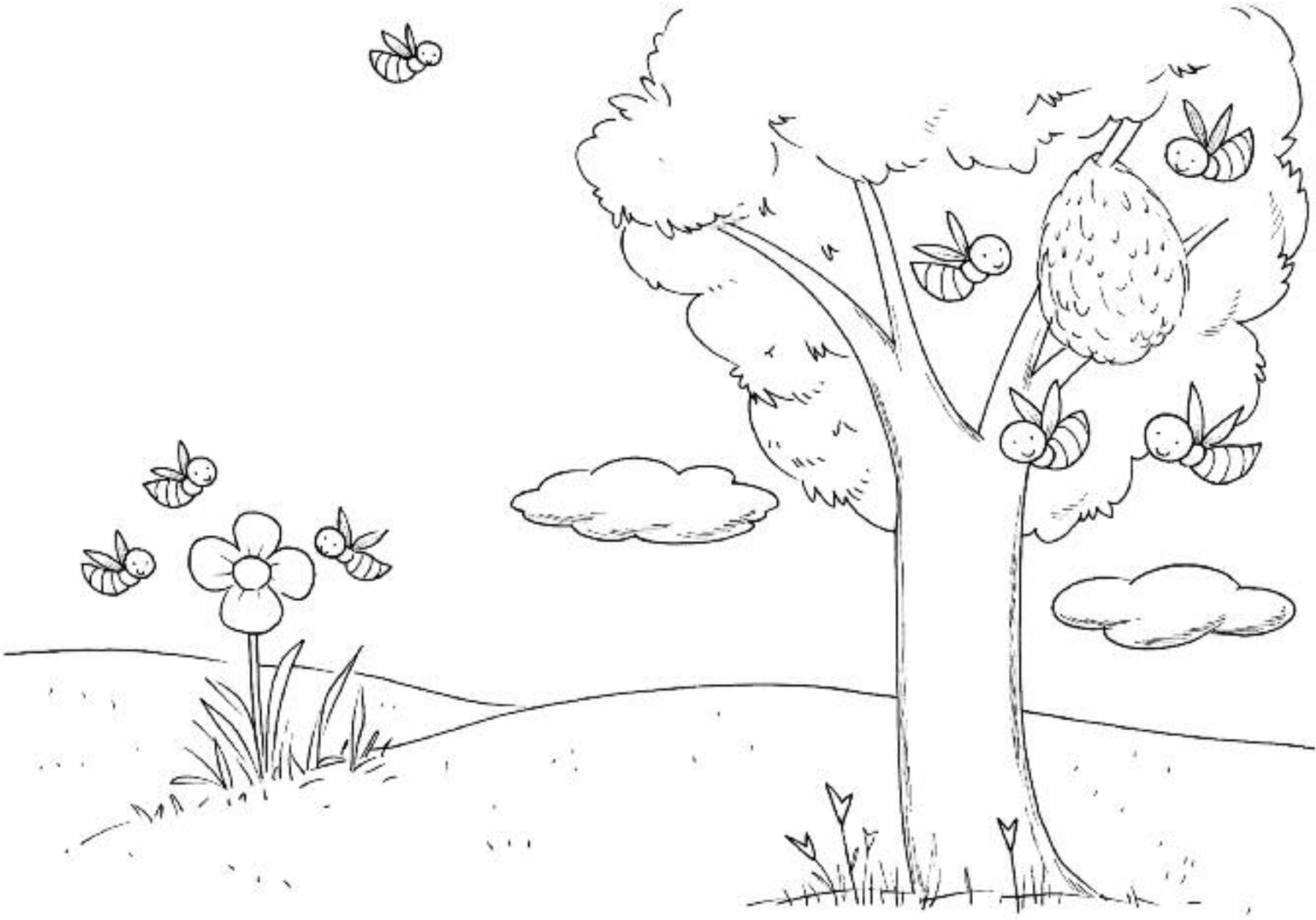

- Recortar los objetos y pegarlos donde corresponden según sean pesados o ligeros.

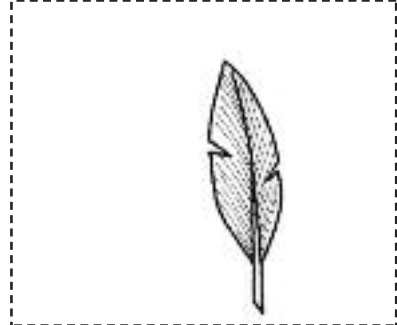
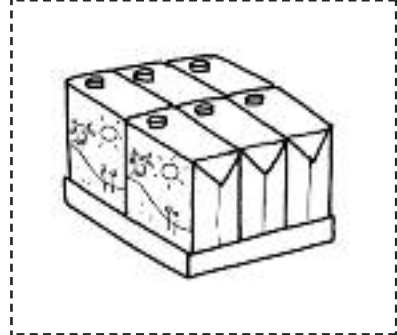
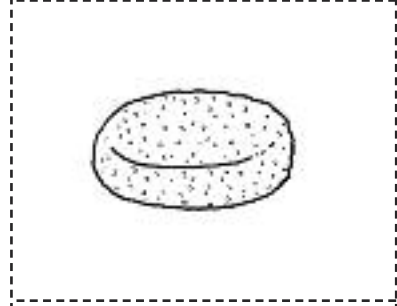
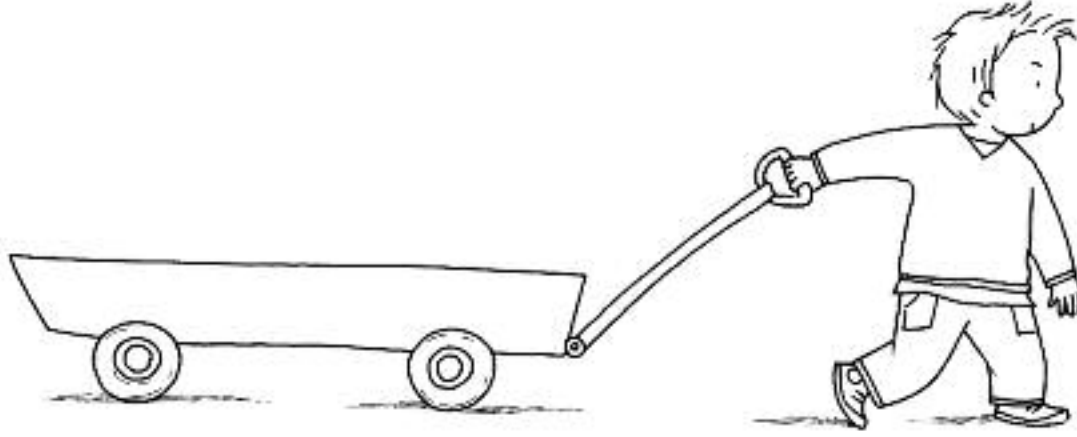
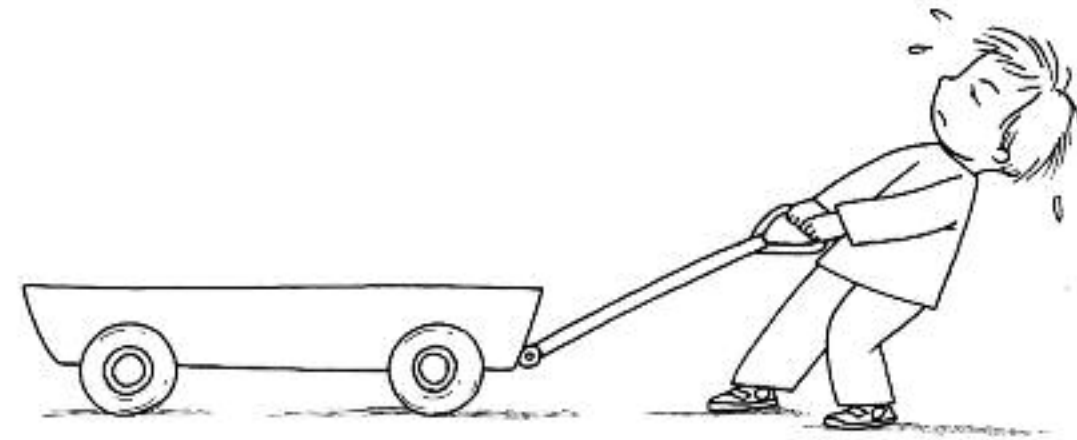

- Colorear de verde los tejados de las casas que tienen más ventanas que el modelo y de naranja los de las casas que tienen menos ventanas que el modelo.



- Dibujar los elementos que resultan al juntar los dos grupos y escribir el resultado.

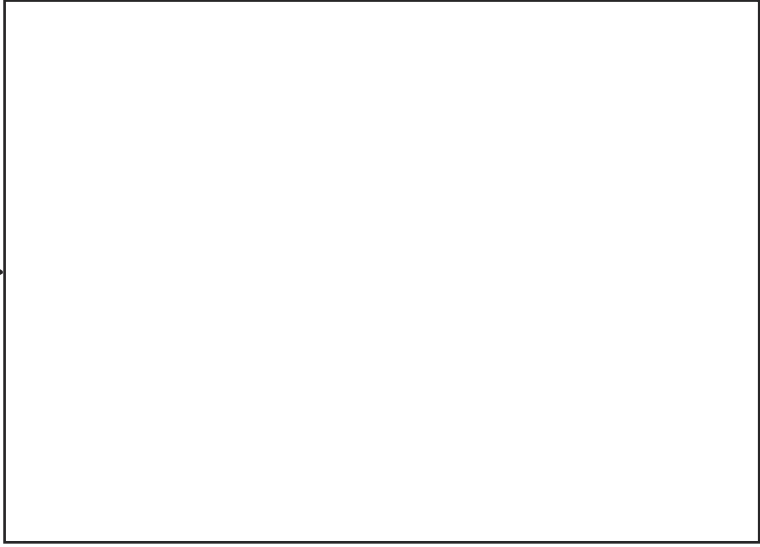
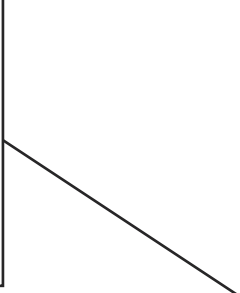
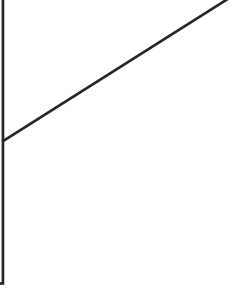
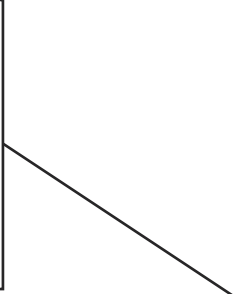
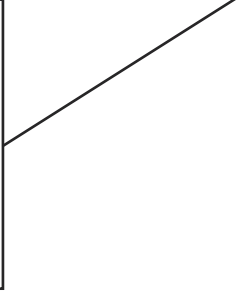
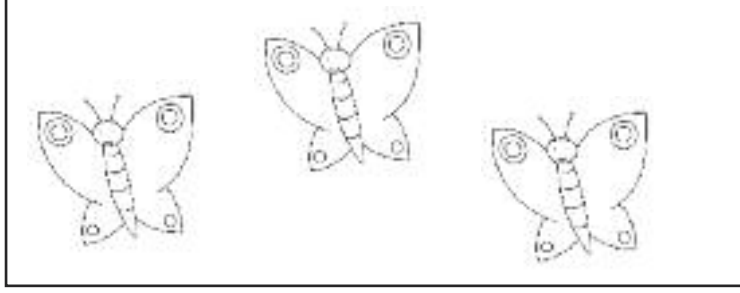
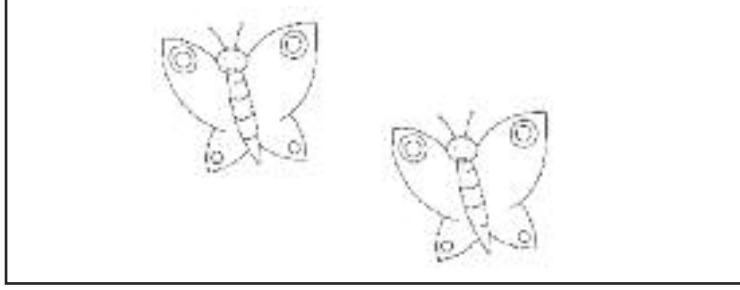
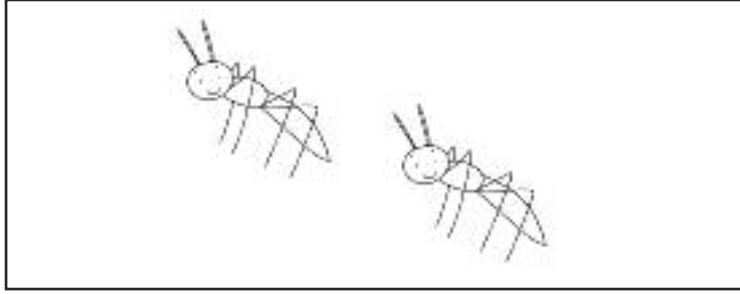
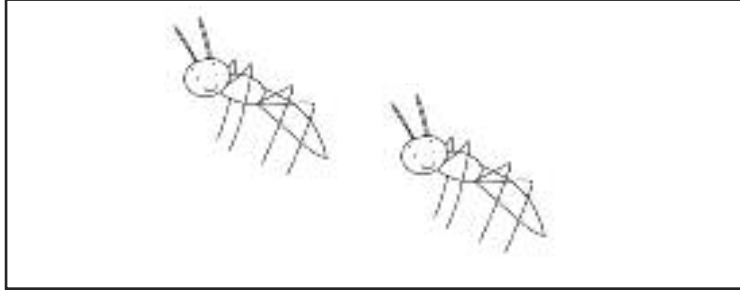

- Trazar un camino para que el topo llegue a la galería y colorearlo.

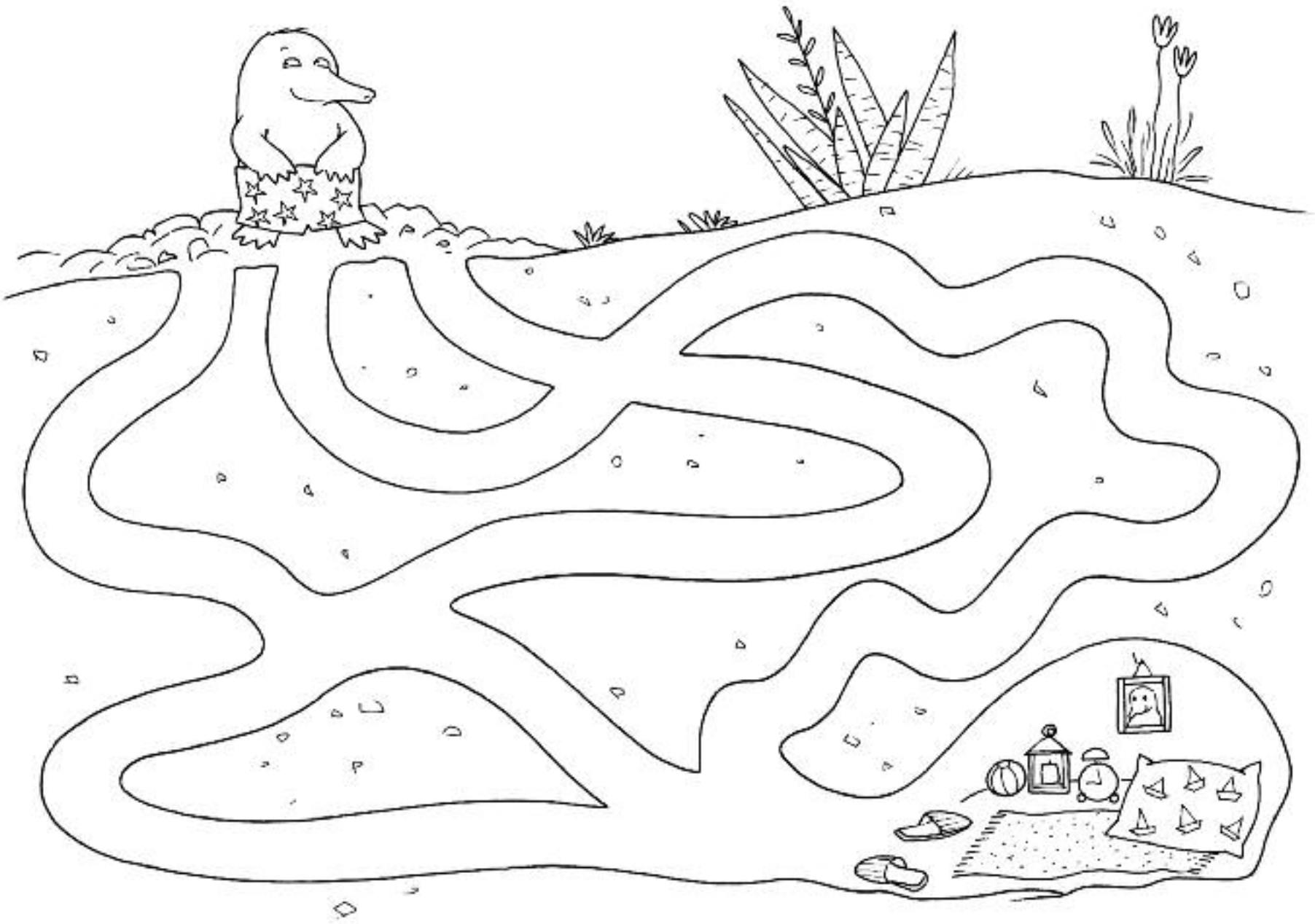

- Buscar los cinco errores de la escena de primavera.

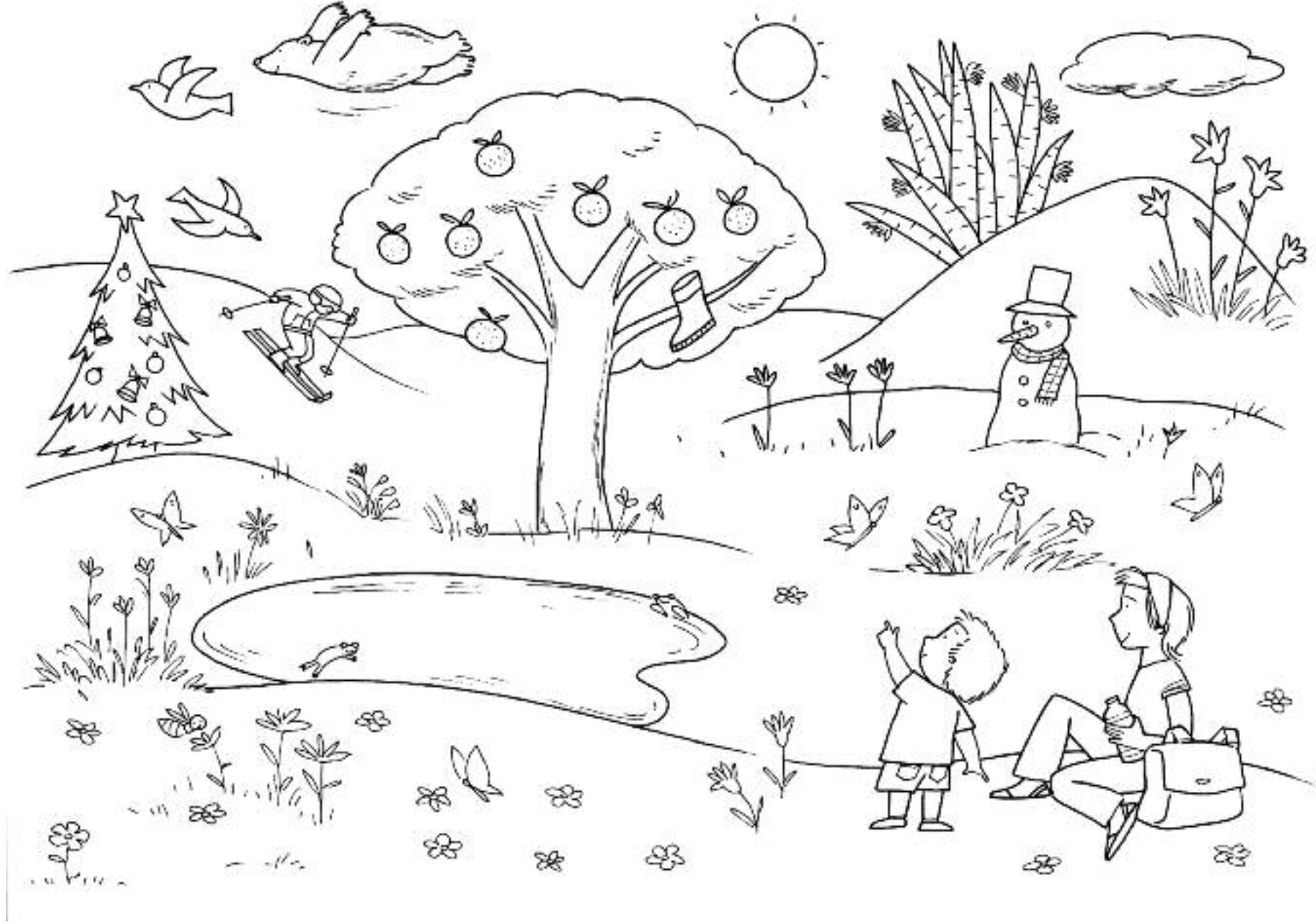



- Dibujar algún animal marino entre la roca y las algas.

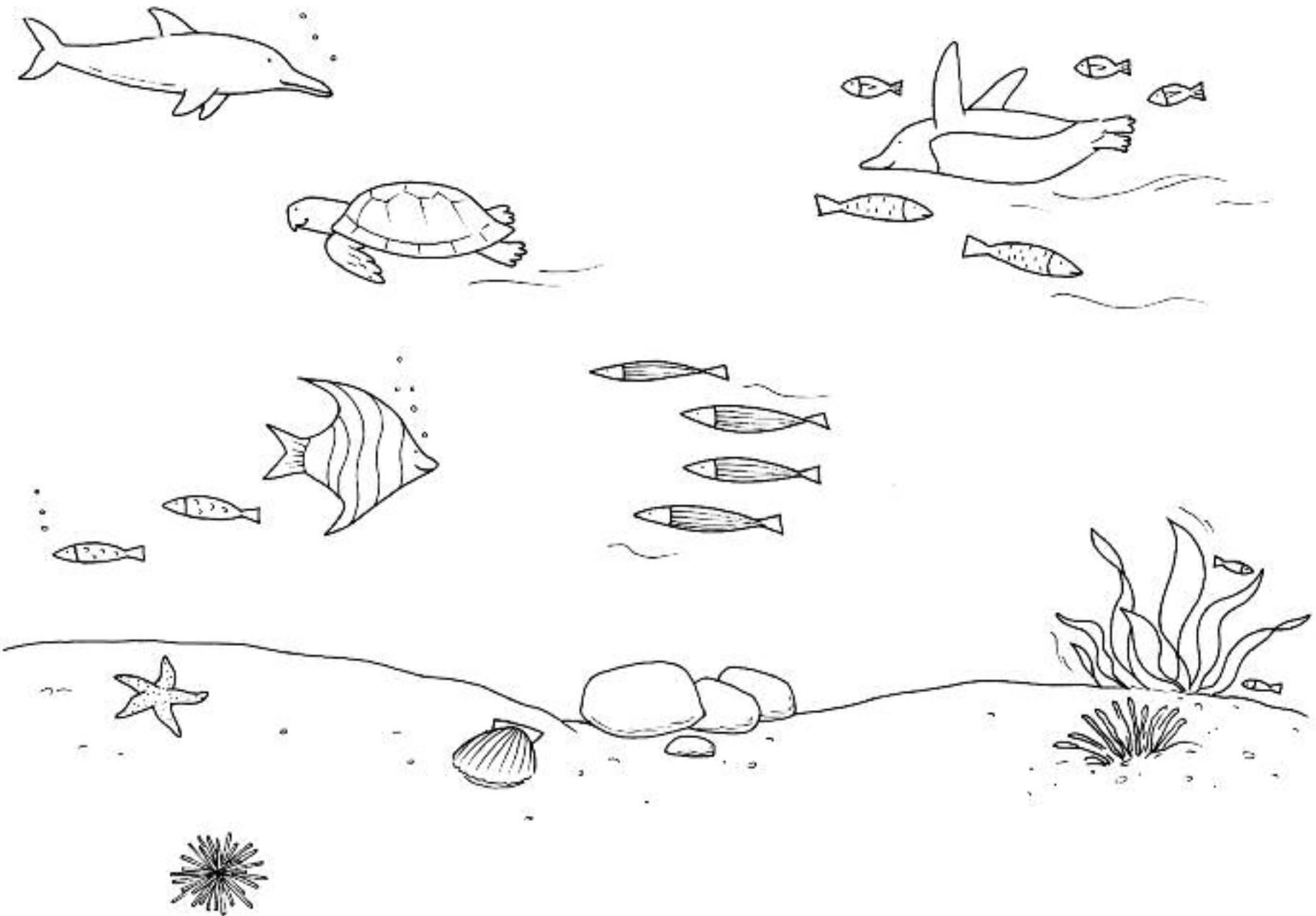

- Realizar las series.

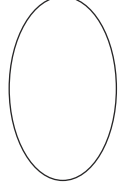
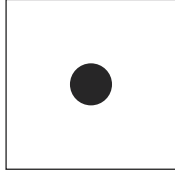
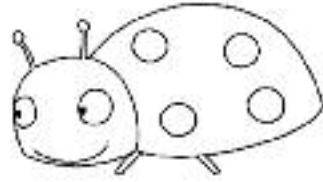
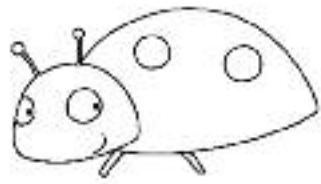
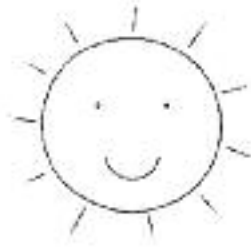

- Escribir los números que corresponden para completar y resolver las sumas.

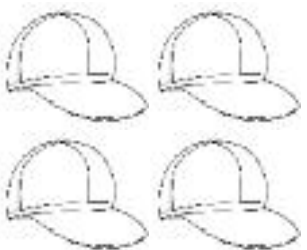

+



=



+



=

- Unir cada animal con el medio por el que se desplaza.
- Colorear al animal más lento.

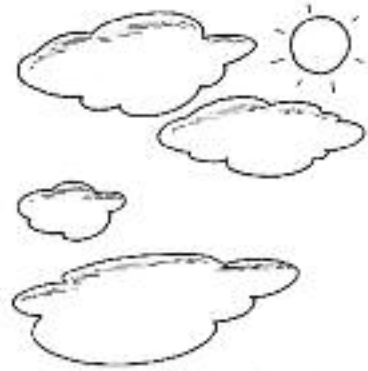
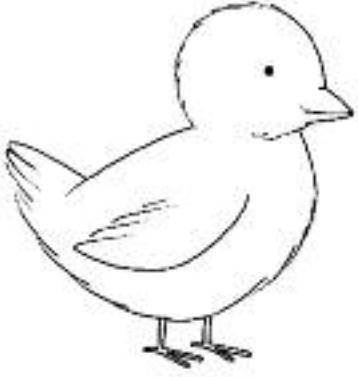
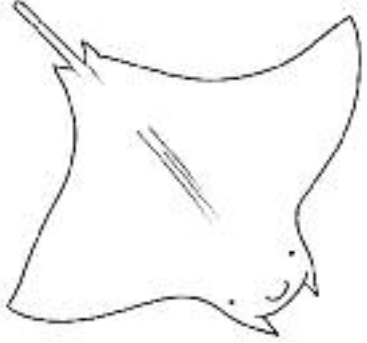
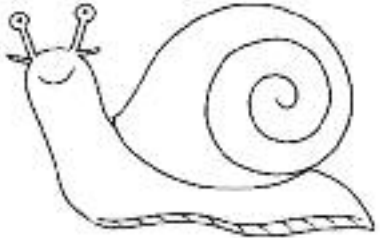



- Repasar las grafías del 6.
- Colorear seis hojas de la planta.

Handwriting practice section for the number 6. It consists of six rows of horizontal lines. Each row contains a solid number 6 with a starting dot and arrow, followed by a dotted number 6 for tracing, and then five horizontal lines with starting dots and arrows for independent practice.

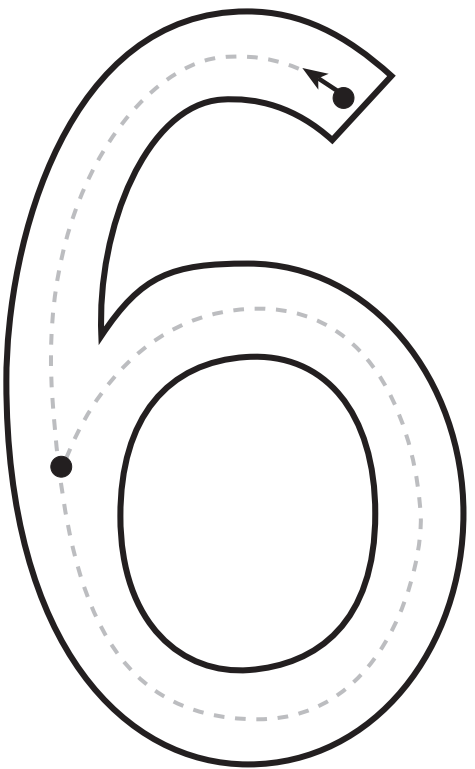

- Dibujar las manchas necesarias para que todas las vacas tengan seis.

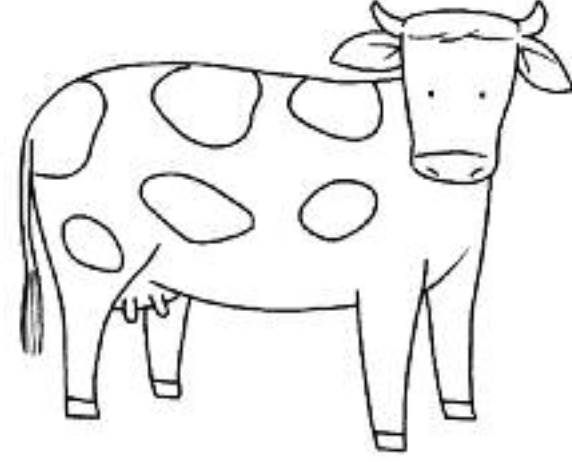
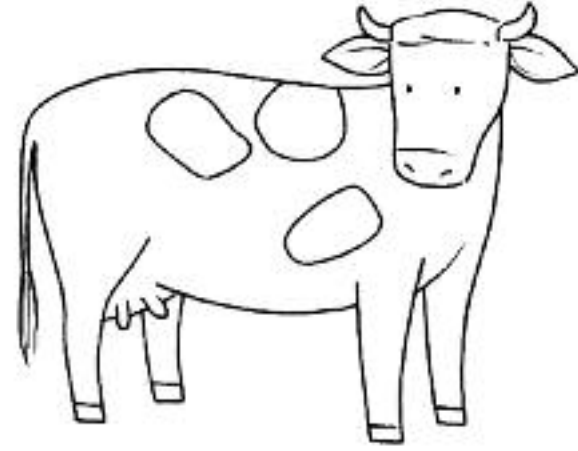
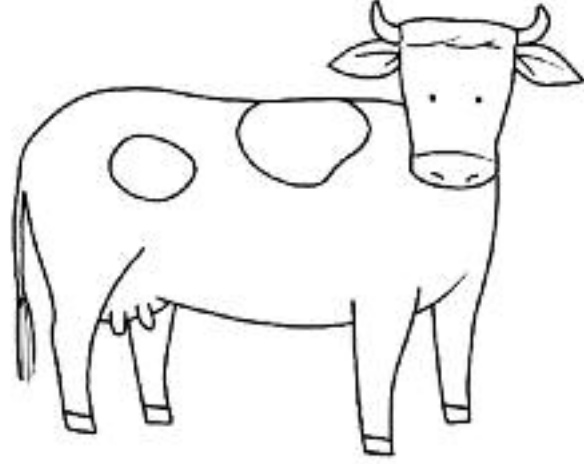
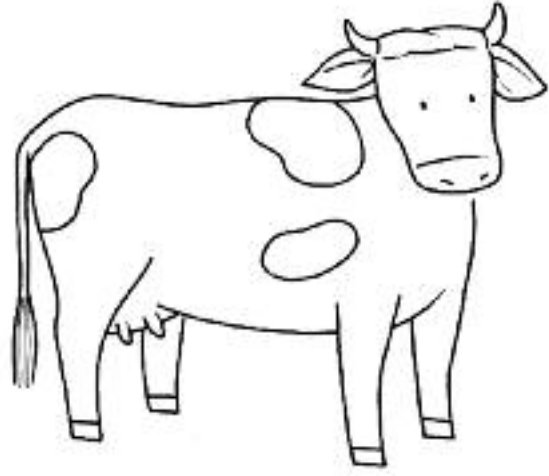



- Encontrar el animal marino escondido y colorearlo.

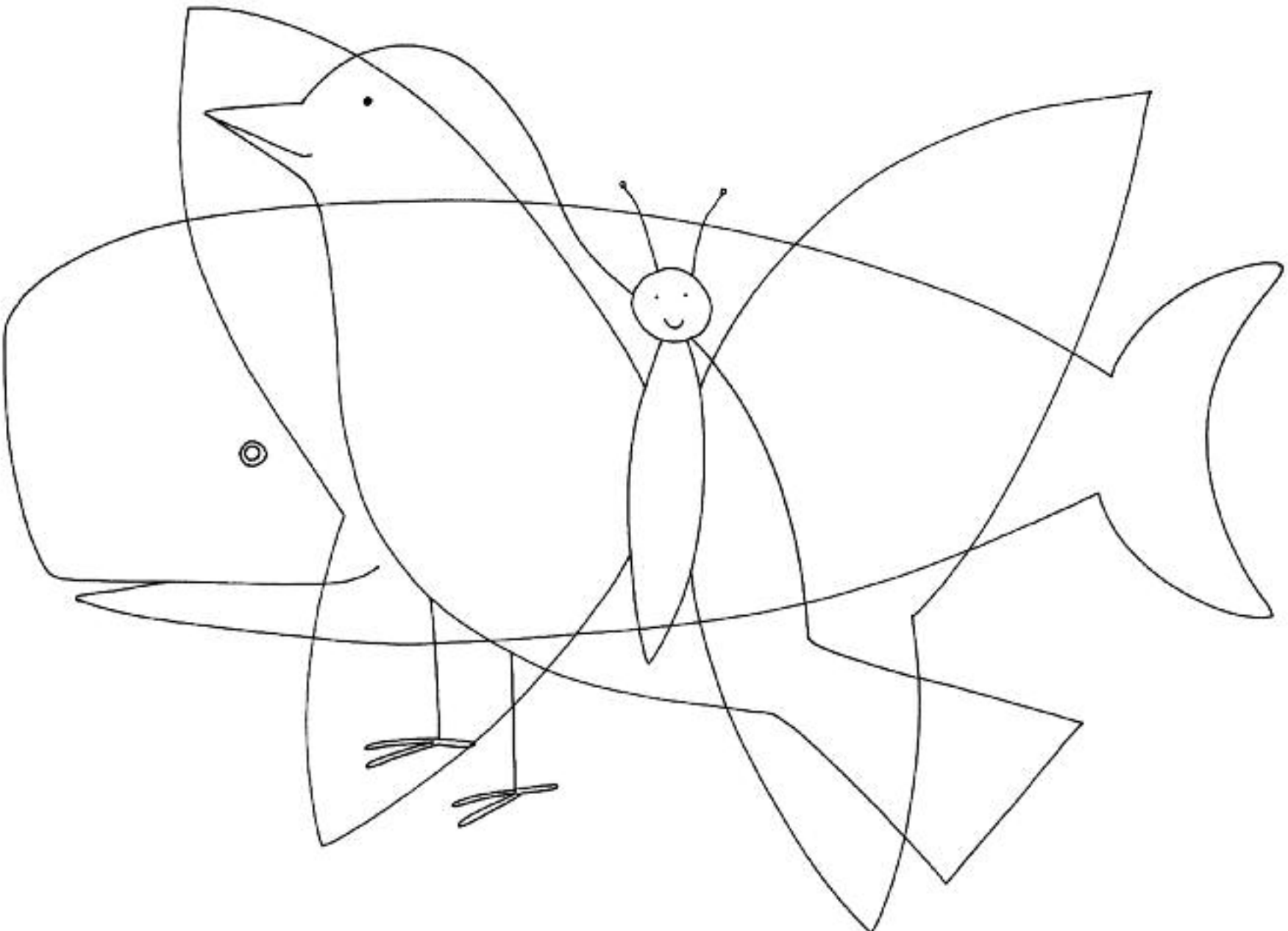

- Colorear al animal que es más alto que el árbol.





UNIDAD 9

- Unir los números por orden para descubrir el dibujo escondido.
- Dibujar seis nubes en el cielo

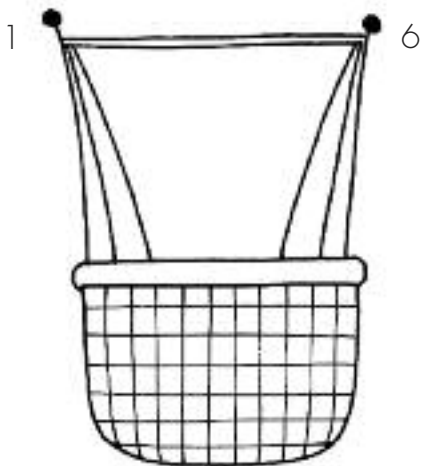
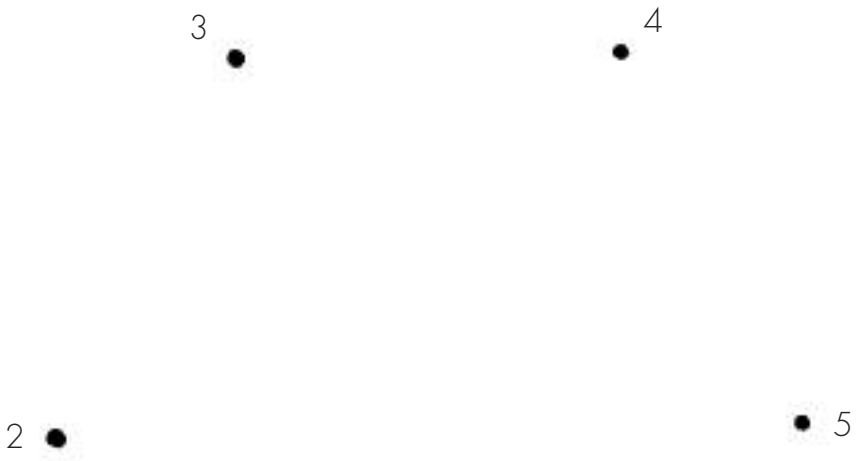

- Tachar los vehículos que tienen ruedas. Tachar los vehículos que no se desplazan por el aire. Colorear los que quedan.

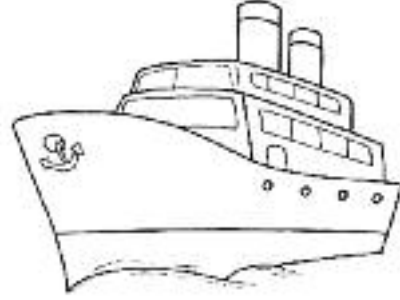
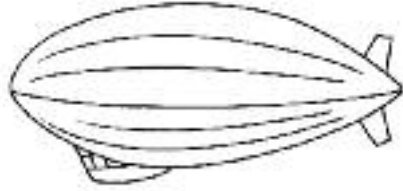
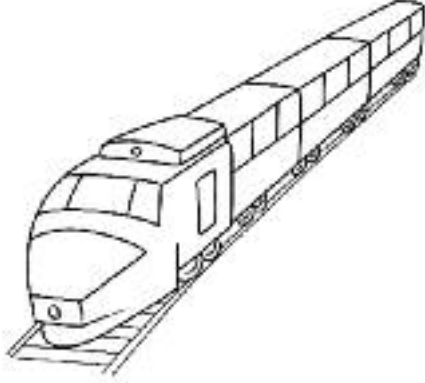
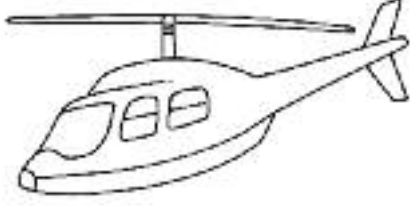
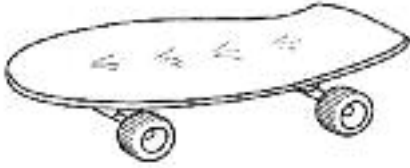



- Escribir los números que corresponden para completar y resolver las sumas.



+



=

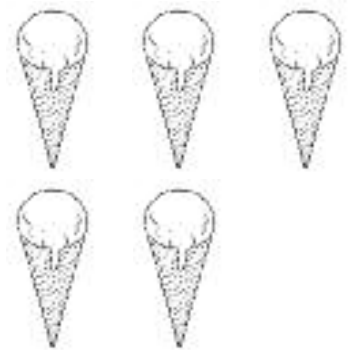

+



=

- Contar el número de toallas, barcos, gaviotas y sombrillas que aparecen en la escena y escribirlo en la casilla correspondiente.

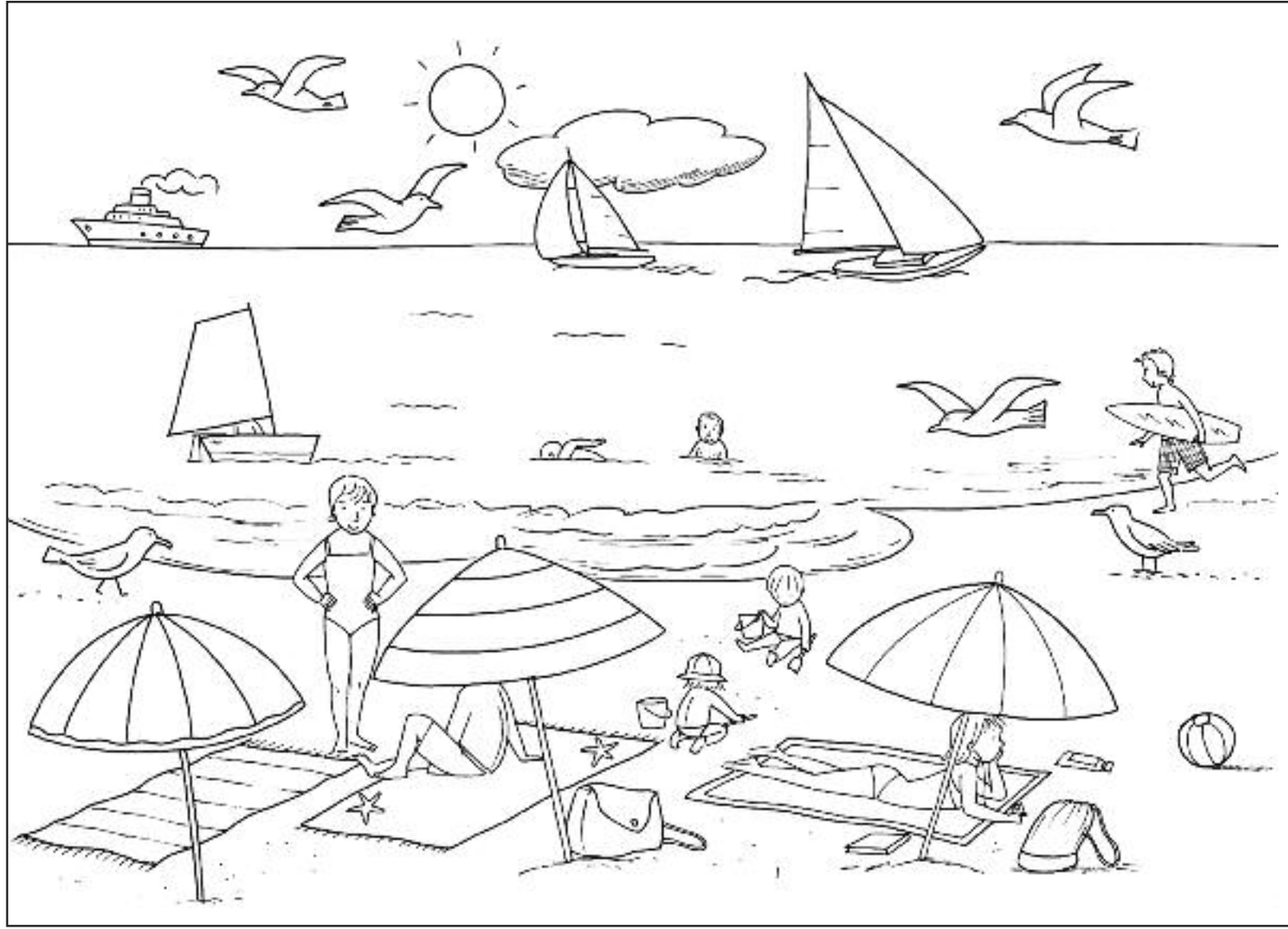









UNIDAD 9

- Observar los dibujos tratando de memorizarlos. Doblar la hoja por la mitad y dibujarlos.

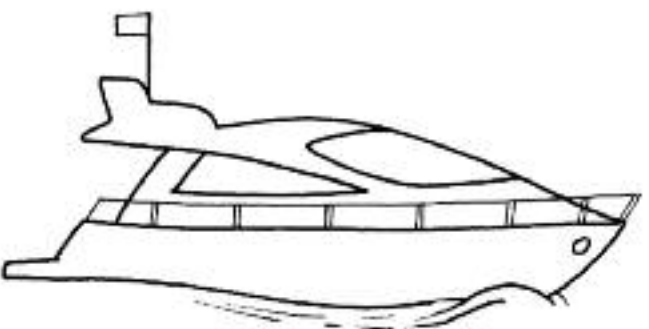
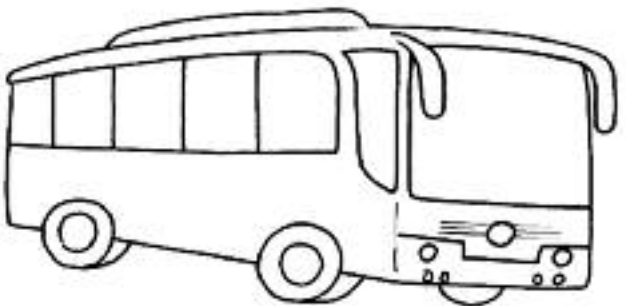
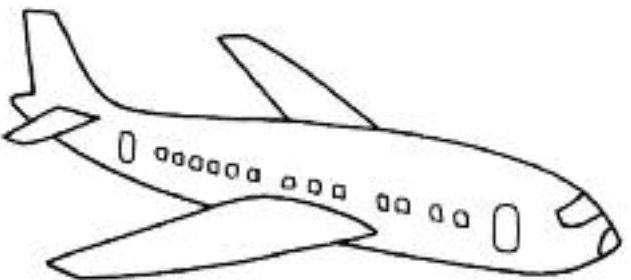

- Repasar los números y rodear en cada fila tantos elementos como indican.

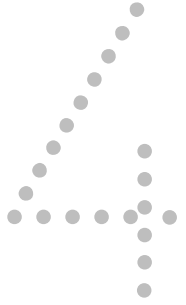

- Dibujar un helado en la mano derecha del niño.
- Colorear la sombrilla que está a la izquierda del niño.

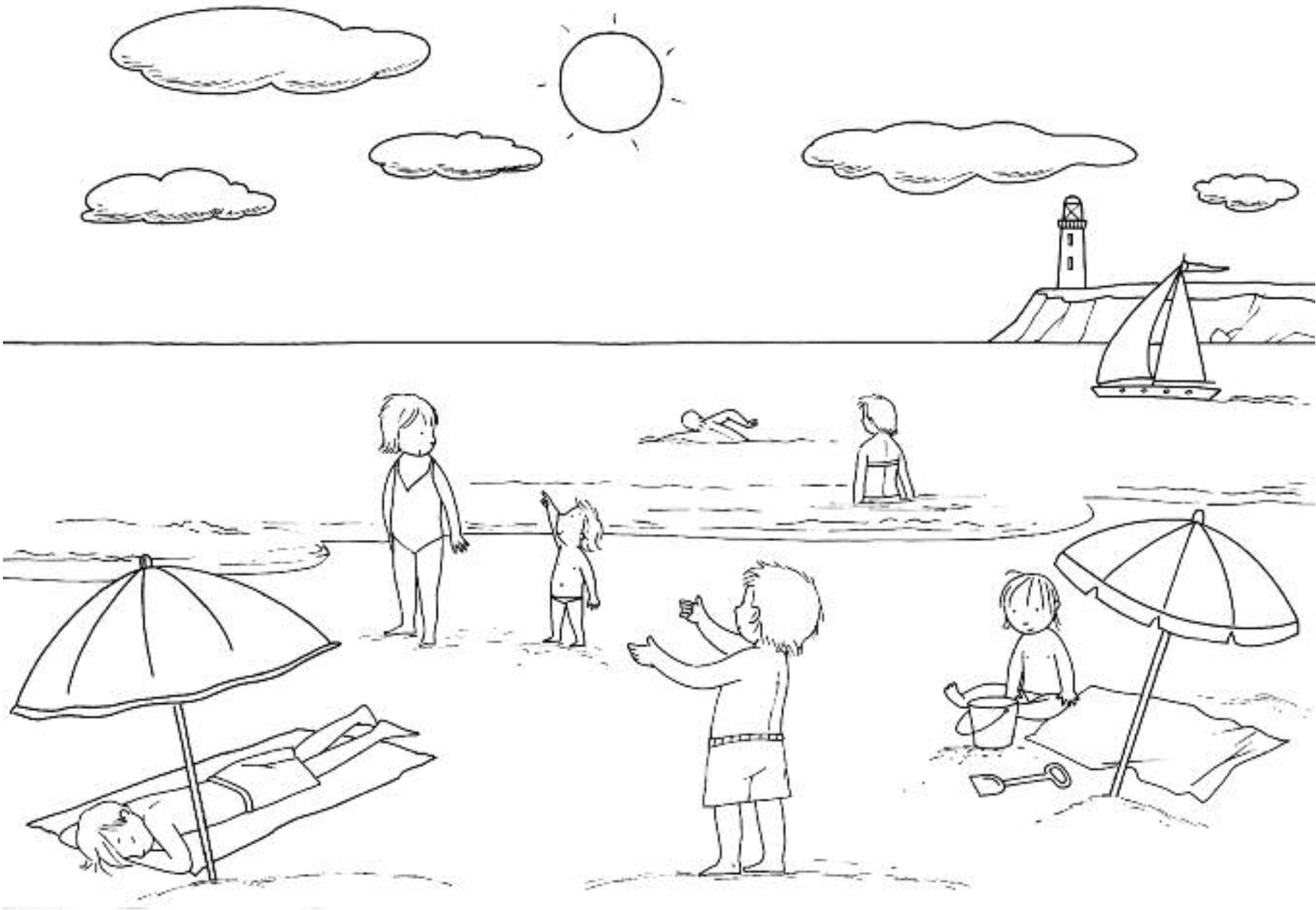

- Escribir los números o dibujar los elementos para completar y resolver las sumas.

3



+

2

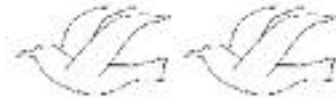

=



+

2

=

1

+



=



UNIDAD 9

- Unir cada figura con su silueta.

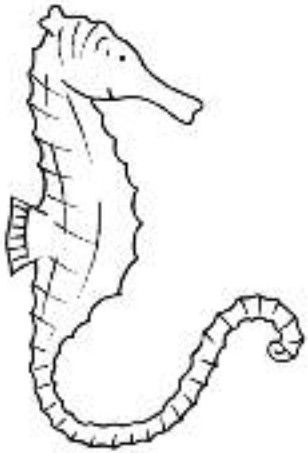
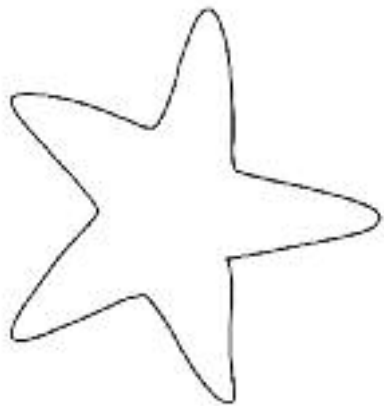
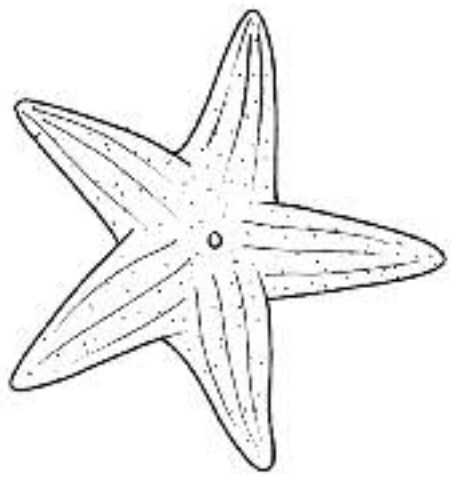
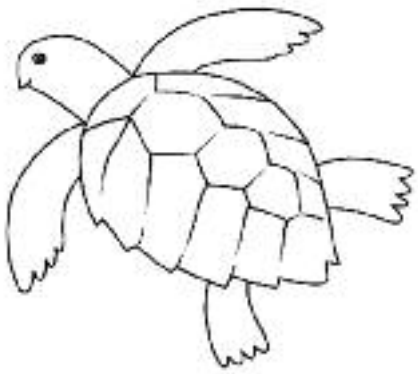
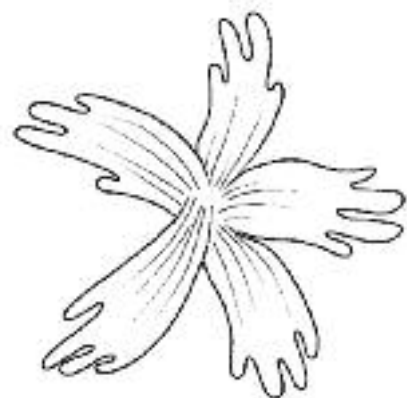

- Repasar y completar las grafías del 7.
- Buscar los números 7 escondidos y colorearlos.

